



# A Low-Cost Light Fidelity Prototype Designed for Patients' Status Transmission in Benin Hospital

Max Fréjus Owolabi Sanya<sup>1,2\*</sup>, Fifamè Merci-Ange Magnidet<sup>2</sup>, Sabi Yari Moïse Bandiri<sup>3</sup> and Anais A Nassara<sup>1</sup>

<sup>1</sup>Department of Computer Science and Telecommunications of Polytechnic School of Abomey-Calavi (EPAC), University of Abomey-Calavi, Benin

<sup>2</sup>LETIA, Ecole Doctorale Sciences De l'Ingenieur ED-SDI, University of Abomey-Calavi, Benin

<sup>3</sup>Institute for Engineering and Sustainable Development (IEDS), University for the International Integration of the Afro-Brazilian Lusophony (UNILAB) Redencao, Brazil

**Submission:** October 26, 2023; **Published:** December 08, 2023

**\*Corresponding author:** Max Fréjus Owolabi Sanya, Department of Computer Science and Telecommunications of Polytechnic School of Abomey-Calavi (EPAC), University of Abomey-Calavi, Benin

## Abstract

In hospitals, there is a lot of medical equipment's that is sensitive to monitor patients' status. In this condition, it is prohibited of using Wi-Fi especially in the case of intensive care unit due to probable interference between Wi-Fi radio waves and hospital operation equipment's. To overcome such restrictions, this work proposes to design a low-cost LiFi prototype for data transmission between two medical equipment's in hospital. LiFi is based on LED light bulbs through which data can be transmitted. Meanwhile, it doesn't interfere with medical equipment's, since LiFi uses illumination for data transmission. In this paper, we built a prototype using accessible tools and platforms such as Arduino with hardware and software. The designed prototype allows text and image transmission between two equipment's using an LED and a photodiode. After many experimental tests, we showed the possibility to transmit data rate of 115,200 bits/s throughput over 2,5cm using the LiFi prototype designed. To the best of our knowledge, this is the first Benin LiFi transmission that opens the way for huge possibilities of projects.

**Keywords:** LiFi, VLC, LED, Arduino

**Abbreviations:** Wi-Fi: Wireless Fidelity; VLC: Visible Light Communication; IM: Intensity Modulation; DD: Direct Detection; LOS: Line of Sight; OSI: Open Systems Interconnection

LiFi : Light Fidelity; LED : Light Emitting Diode ; LASER : Light Amplification by Stimulated Emission of Radiation

## Introduction

Communication has always been a necessity for humans. This growing and ever more demanding need has enabled the evolution of data transmission solutions. Radio frequency communications have been the most widely deployed and continue to be exploited. In hospitals, there is much critical care equipment operating to monitor patients' medical status. For hospital personals to monitor their patient's status, they must use their own device, such as cellphone or desktop computer through data communication. If we used Wi-Fi at the same place as medical equipment, electromagnetic interference may occur and this could induce potentially hazardous events related to medical equipment operations, data security or risks for human health. According to authors [1], in radio frequency interference test with medical equipment, about 20% of the incidents were classified as

hazardous or significant. This will not be good in intensive care rooms where sensitive care medical equipment could malfunction if this happens. Due to this reason, WiFi connection is limited or prohibited in parts of the hospital building. In this case, only wired communications is used but not practical for mobility usage. A healthier alternative capable of responding to these problems in the hospital consists in using VLC (Visible Light Communication) technology, exploiting wavelengths of visible light spectrum (400 nm - 750 nm) [2,3]. The recent evolution of VLC technology and light-emitting diodes with very fast switching capacity has enabled the birth of LiFi (Light Fidelity). LiFi is a recent technology that can transmit data at high-speed using visible light communication. There are several benefits to using LiFi technology. The first one is that we already have available lighting infrastructure in

our buildings. This means that all the old bulbs can be replaced with LiFi capable bulbs and also the wire to connect them and transmit data on the network. Also, as the flickering rate of the LED bulb for data communication is much faster than the human eye can realize, we can use it as regular light source and the LiFi functionality bulb will be transparent to people in the hospital. Recently, LiFi data transfer rate is shown to be much faster (100 times faster) than that is possible through WiFi [4]. Due to all the described LiFi benefits, it is well suited in hospital areas and many other applications like schools, administration areas, commercial centers, restaurants where light can be used to send data. In this paper, we introduce VLC and LiFi technologies before presenting our proposed LiFi low-cost prototype. The rest of the paper is organized as follows: Section 2 presents the material and methods about LiFi technology and the realized LiFi prototype. Section 3 shows all the results obtained followed by the discussion about the results in Section 4. Finally, Section 6 will conclude this paper with possible future works after describing the development contribution of the work in Section 5.

### Material and methods

VLC systems work on the concept of transmitting data through a light source which can be an LED or a LASER diode. However, LEDs are preferred due to their low cost and large emission surfaces, allowing more diffuse optical beams to be produced, thus facilitating compliance with lighting constraints as well as those related to eye safety [5]. Due to the lighting function that VLC systems must ensure, Intensity Modulation and Direct Detection (IM/DD) in direct visibility (or LOS: Line of Sight) is generally implemented [2,6,7]. Indeed, in the VLC transmitter, intensity modulation is implemented by directly modulating an LED and controlling the intensity of its optical radiation. The emitted optical wave is propagated in the channel and then detected by a receiver. The incident wave is then transformed into a proportional current [8,9]. Thus, the VLC transmitter transforms the information into data compatible with the optical medium while the receiver converts the detected optical signal into electrical to extract the information [6]. Apart from an operation like that of VLC systems, LiFi is an analogy with that of WiFi commonly used today to talk about VLC technology. Indeed, VLC is a unidirectional and point-to-point optical communication technology [10-12]. On the other hand, LiFi allows two-way communications that support multiple accesses to data and user mobility thanks to the networking of LED lamps [13]. Additionally, LiFi is a downlink VLC with infrared uplink. LiFi, then, extends the concept of visible light communication (VLC) to achieve high-speed, secure, two-way wireless communications using powerful LEDs or LED lamps [14]. Such LiFi system comprises a transmitter block and a receiver block with respectively an LED and a photodetector. Figure 1 [11] shows an example of LiFi link. The information data that comes from the Internet is used to modulate an LED Lamp via a driver. At the receiver, a dongle composed of a photodetector with an

electronic processing block is used to recover the data.

To design the LiFi prototype, the proposed system is based in hardware with developed software implemented on it. We used two computers as medical equipment and designed the various necessary circuitry cards (for both the emitter and receiver boards). The implemented software allows us to test the prototype during the experimentation phase. To achieve this, model OSI (Open Systems Interconnection) is applied [15]. As physical medium, here, cards equipped with LEDs and photodiodes respectively are used to transmit and receive the information data (Cf. Figure 2). Indeed, according to (Figure 3), we can see an LED and photodiode which respectively are associated with a conditioning block. The conditioning block has the role to process an input signal to provide output which will be easily perceptible and understandable by a microcontroller used in both emitter and receiver card. The latter brings together amplification and filtering sub-blocks. Each microcontroller receives (or sends) a signal to transmit the resulting signal into a computer (or conditioning block). For the experimentation, Arduino Uno microcontroller is used. In addition, the two cards are each one powered by a 5V DC voltage supplied by a computer USB port. As hardware cannot function alone, software layers are necessary to ensure the information data sending and receiving. All the prototype physical and logical architectures are based on an OSI model and shown by (Figure 3).

With the established architecture, a large choice of material could be used for the hardware and software point of view. Here, we have decided to use accessible and low-cost tools with open-source software to achieve our objective. Remember that we want to prove that it is feasible to send data through visible light spectrum between medical equipment. In the emitter card, we chose a standard white LED with a voltage of about 3,4V at a bias current of 20 mA. For the receiver card, the optical light detection is ensured by a BPW34 photodiode. This photodiode is available in the market and works in both the infrared (IR) and visible light spectrum. It allows acceptable detection in the visible spectrum with less sensitivity to external disturbances (like other light sources close to its immediate environment). The prototype implementation was done with Arduino open-source platform as it is quite an intuitive platform, used for building electronic projects. We also use the free Proteus software [16] to design all schematics of the LiFi prototype emitter and receiver circuits. Apart from the Arduino C language coding, we've also coded in Python to implement the second software layer of the prototype. This is done because we have decided to convert all information data into binary sequence. This way of proceeding removed the barrier concerning the type of data to be sent (either this is a text or image, etc.). Hence, the first software layers (in Arduino) with the second one (in Python) allow us to build the serial communication protocol:

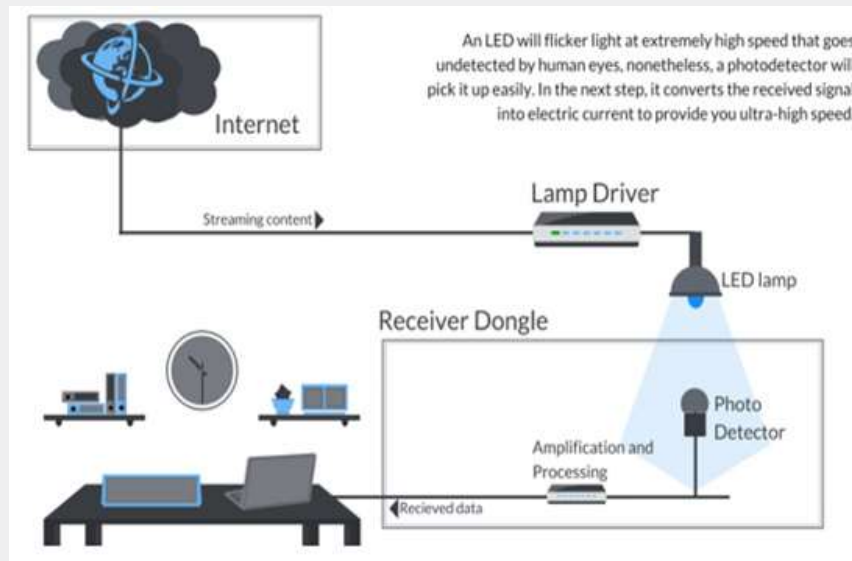

Figure 1: Example of a LiFi link for internet access.

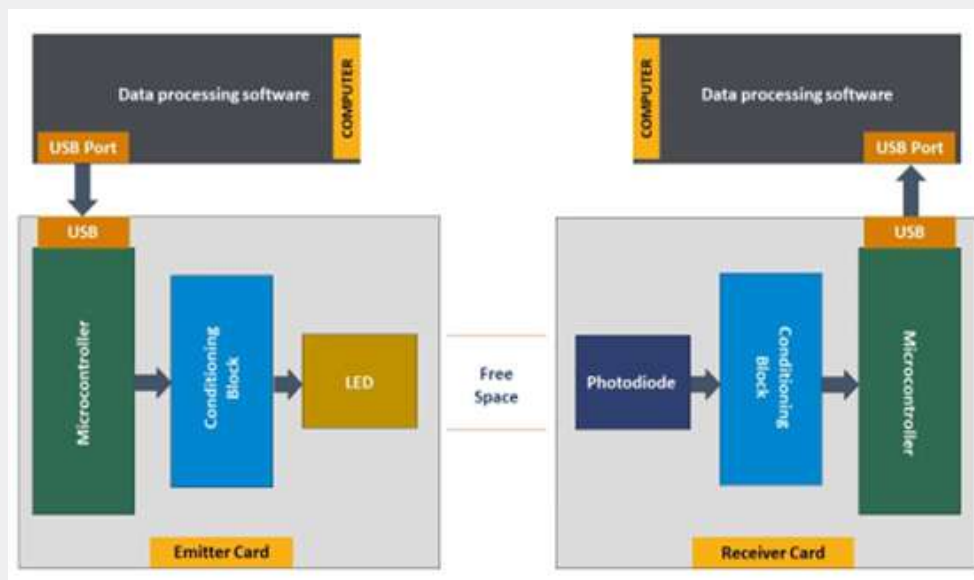

Figure 2: Bloc diagram concept of the LiFi prototype.

- i. communication between the emitter and receiver cards through the LiFi channel (LED + Free Space + Photodiode).
- ii. communication between boards and computers via USB ports.

As the buffer of the serial links is only 64 bytes, data sequencing was carried out to facilitate the transmission. (Table 1) gives an overview of the material we used.

Table 1: Material used.

Material	Characteristics	Quantity
Standard white LED	3,4 V / 20 mA	1
Photodiode (BPW34)	3,4 V $\lambda_1 \in [430 - 1100]$ nm	1
Arduino Uno	14 digital pins 6 analog pins Serial Rx In / Serial Tx Out	2
USB-Serial converter (CH340G)	USB 2.0 Rx In / Serial Tx Out 5 V and 3,3 V Out	2

## Results

In this section, a summary of the design choices made during the project work and the achieved results are described.

### Emitter and receiver cards circuits

As we stated before, the emitter card has a conditioning block. This packaging has an amplification module that should possibly allow the simultaneous use of 3 LEDs. This amplification was done using a 2N2222 transistor. The transistor is connected to port 18 of an ATmega 328P microcontroller, from which a signal data is produced to modulate the intensity light of LEDs. Figure 4 shows an overview of the LiFi emitter card schematic as described. Like the transmitter circuit, the receiver card is built with an ATmega 328P microcontroller. It also includes a BPW34 photodiode associated with a high resistance which acts as a conditioner to convert the photodiode induced photocurrent into a voltage level. At this step, the resulting signal is processed and the received binary data is recovered. (Figure 5) shows an overview of the corresponding LiFi receiver card schematic. According to the proposed architecture (Figure 3), we obtained the functional LiFi prototype presented at (Figure 6) [17]. This prototype is composed of two cards (emitter and receiver) that could be connected by USB to a terminal (computers or medical equipment).

### Experimentation Results

The prototype's software layers allow transmission of "text" or "black and white" image data between two terminals respectively with bit rates of 11,520 bits/s for ASCII texts and 115,200 bits/s for images. At this transmission rate, only a distance of 2,5 cm is achieved with a single LED source as shown by Figure 7 [18]. Figure 8 and Figure 9 show an example of a text transmission by the LiFi prototype. A case of black and white image transmission is also shown by Figure 10. For this transmission, the image resolution is set to a value of 12x12 pixels. We also tested high resolution image transmission to estimate the transmission performance in terms of received image quality or transmission time (as shown by Figure 11).

## Analysis

In this section, we discuss about results obtained in Figure 6. Firstly, based on results from Figure 8 and Figure 9, we demonstrate that it is possible to transmit a "text" data using the prototype without error transmission. We also prove the feasibility of "image" transmission using the same prototype. However, for images beyond 12x12 pixels resolution, there is a pixel loss or images corruption. Likewise, for "text" transmission beyond 34 ASCII characters, some errors occur in the received text. This is normal and could be explained by the physical limitations in terms of speed and buffer memory of the used microcontroller in the experiments. As our objective to design a low-cost LiFi prototype and demonstrate its feasibility to transmit data "text" and "image" through visible light is proved, and now real, we can say that the designed prototype works perfectly and could be improved for real applications like hospital area. According to result from Figure 7, we can see that distance transmission for the experienced "text" and "image" LiFi transmission is only 2,5 cm at respectively bit rate of 11,520 bits/s for ASCII text transmission and 115 200 bits/s for image. This is because we have already reached the performance limitations of the prototype hardware at these data rate values. However, to reach more than 2,5 cm transmission with the proposed LiFi prototype, we need to decrease the data rate transmission as it is shown in papers [13,19]. But if high distance transmission is needed, we must design a more complex prototype LiFi with high electronic and processing components. In addition, for the case of image transmission, the transmission time increases with the image resolution. This is quite normal due to the high information volume to send when having high image resolution to emit.

## Conclusion

This paper demonstrates the possibility to realize in a low-cost manner a data transmission between two terminals of medical equipment through visible light spectrum. The proposed LiFi prototype is designed using accessible tools and platforms such as Arduino and optoelectronic components available in

the Benin market. For this proof of LiFi prototype concept, we demonstrate transmission of “text” and “image” at throughput of 115,200 bits/s over a maximum distance of 2,5 cm via visible light source. The use of efficient LEDs and photodiodes dedicated to the

visible light transmission in addition to very powerful on-board electronics processors such as Raspberry Pi or FPGA should make it possible to carry out more interesting LiFi applications.

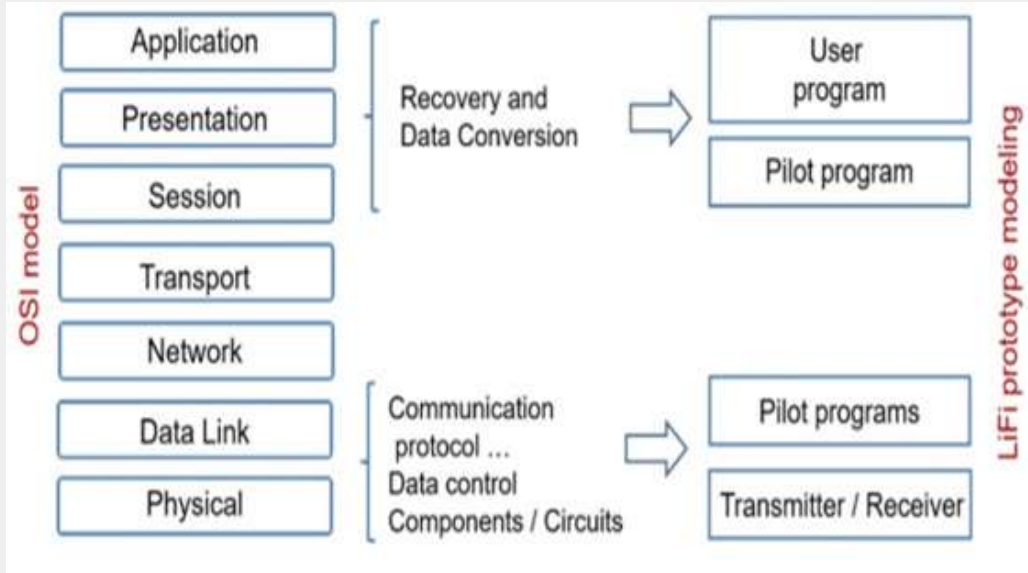

Figure 3: Bloc diagram of the designed LiFi prototype architecture.

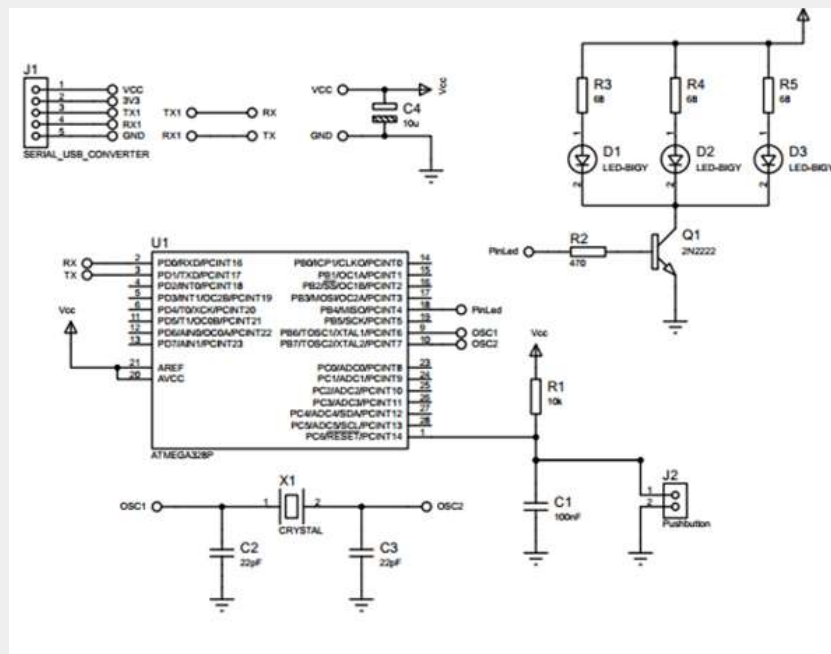

Figure 4: Emitter circuit of the designed LiFi prototype.

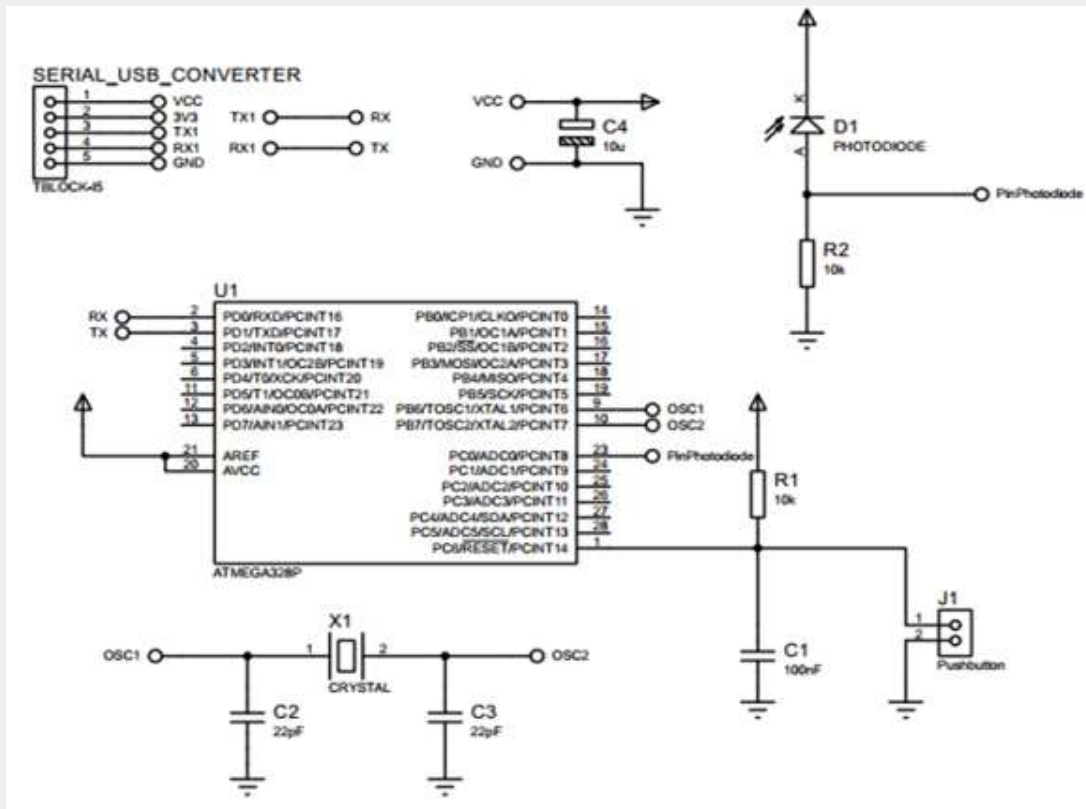

Figure 5: Receiver circuit of the designed LiFi prototype.

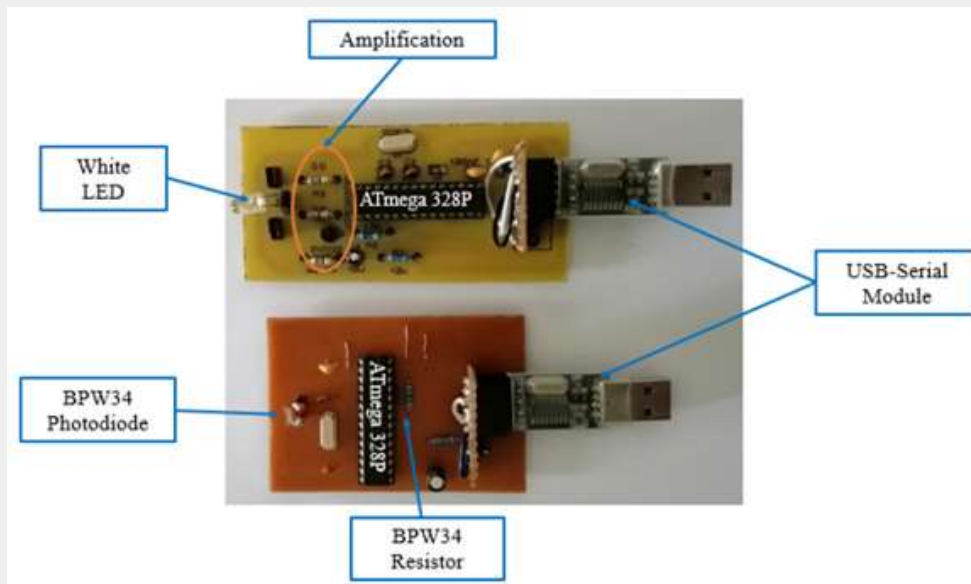

Figure 6: View of the designed LiFi prototype.

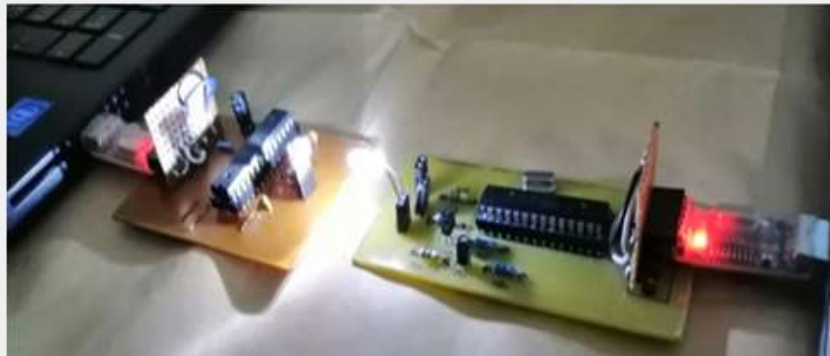

Figure 7: LiFi prototype connecting two computers for test.

```
Shells
Python
Type 'help' for help, type '?' for a list of *magic* commands.
Running script: "C:\Users\Anais\Desktop\LiFi_memoire_docs\Moi\lifi_no_python\Lifi_arduino_python_serial\Lifi_Fichier_Serial\Fichier_em
Ouverture du port...
Ouverture..
Ouvert..
Welcome with Li-Fi 2021
Fin traitement et pret pour l'envoi
Saisir ok pour lancer l'envoi et q pour quitter: ok
Etablissement de la communication...
Fin d'établissement de la communication...
Fin de la transmission de donnees
Saisir ok pour envoyer à nouveau et q pour quitter:
```

Figure 8: The text "Welcome with Li-Fi 2021" is sent.

```
Shells
Python
Kernel process terminated for restart. (0)
Python 3.7.0 (v3.7.0:1bf9cc5093, Jun 27 2018, 04:06:47) on Windows (32 bits).
This is the Pyzo interpreter with integrated event loop for ASYNCIO.
Type 'help' for help, type '?' for a list of *magic* commands.
Running script: "C:\Users\HP\Documents\Anais\LiFi_memoire_docs\Moi\lifi_etape_17\Lifi_arduino_python\Lifi_arduino_python_serial\Lifi_Fichier_Serial\Fichier_reception_serial.py"
Ouverture du port...
Ouverture..
Ouvert..
Saisir ok pour lancer la reception et q pour quitter: ok
Reception..
Le texte reçu
Welcome with Li-Fi 2021
Le taux d'erreur par caractere est
0
Avec les carateres erronees aux positions:
Saisir q pour quitter ou ok pour recevoir à nouveau: |
```

Figure 9: The text "Welcome with Li-Fi 2021" is well received.

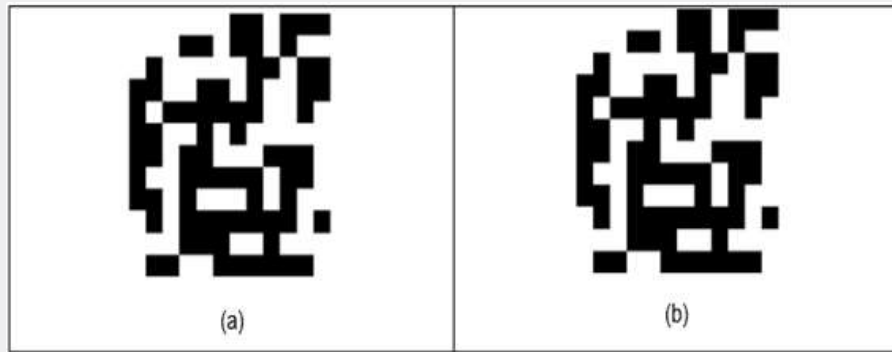

Figure 10: Image of 12x12 pixels – (a) sent, (b) received.

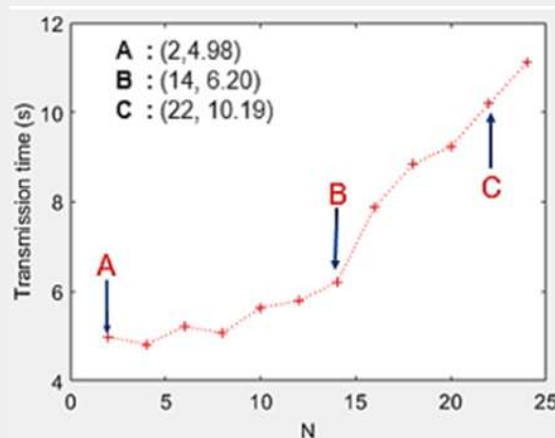

Figure 11: Performance of the transmission time versus the image resolution (N).

## References

1. Van Der Togt R, Van Lieshout EJ, Hensbroek R, Beinat E, Binnekade JM, et al. (2008) Electromagnetic interference from radio frequency identification inducing potentially hazardous incidents in critical care medical equipment. *Jama* 299(24): 2884-2890.
2. Dimitrov S, Haas H (2015) Principles of LED light communications: towards networked Li-Fi. Cambridge University Press.
3. (2022) Pourquoi et comment communiquer en Optique Sans Fils: de l Infrarouge au Li-Fi Anne Julien-Vergonjanne.
4. MacDonald F(2022) A New Type of Li-Fi Has Reportedly Cracked 40 Gbps, 100 Times Faster Than the Best Wi-Fi. *Science Alert*.
5. Point S, Barlier-Salsi A (2017) Lampes à LEDs et risque rétinien (Fiche technique de la SFRP).
6. Sandah BJPF, Konnon A, Comlan M, Olory B, Sanya MFO (2022) Conception et réalisation d un système de Transmission de données via le LiFi avec l implémentation de la technique de Modulation SIM-OFDM.
7. Medina C, Zambrano M, Navarro K (2015) Led based visible light communication: Technology, applications and challenges-a survey. *Int J Adv Engineer Tech* 8(4): 482.
8. Cevik T, Yilmaz S (2015) An Overview of Visible Light Communication Systems. *International Journal of Computer Networks and Communications* 7(6): 139-150.
9. Blinowski G (2015) Security issues in visible light communication systems. *IFAC-PapersOnLine* 48(4): 234-239.
10. (2022) Theses.fr – Clément Le Bas, Système de télésurveillance médicale utilisant la technologie de transmission optique sans fil.
11. (2019) LiFi vs WiFi: Why LiFi will not be able to replace WiFi? GreyB.
12. Ramananda D, Sequeira AM, Raikar SR, Shanbhag CK (2019) Design and Implementation of LiFi Communication system. *IOP Conf. Ser. Mater Sci Eng* 594(1): 012041.
13. Goswami P, Shukla MK (2017) Design of a Li-Fi Transceiver. *Wireless Engineer Tech* 8(4).
14. Duque A (2022) Global LiFi Congress: the Good, the Bad and the Ugly by Alexis Duque *Medium*.
15. Day JD, Zimmermann H (1983) The OSI reference model. *Proceedings of the IEEE* 71(12): 1334-1340.

16. (2022) Supply frame 'Proteus Loader Download. Component Search Engine.
17. NASSARA AGA (2022) 'Mémoire\_prototype\_Lifi\_corrige.pdf. Google Docs.
18. Max Sanya (2021) Transmission de données par LiFi entre deux ordinateurs (GIT/EPAC, Bénin).
19. Vinnarasi A, ST Aarthy (2017) "Transmission of data, audio signal and text using Li-Fi. Int J Pure Appl Math 117(1): 179-186.



This work is licensed under Creative Commons Attribution 4.0 License  
DOI: [10.19080/RAEJ.2023.05.555670](https://doi.org/10.19080/RAEJ.2023.05.555670)

**Your next submission with Juniper Publishers  
will reach you the below assets**

- Quality Editorial service
- Swift Peer Review
- Reprints availability
- E-prints Service
- Manuscript Podcast for convenient understanding
- Global attainment for your research
- Manuscript accessibility in different formats

**( Pdf, E-pub, Full Text, Audio)**

- Unceasing customer service

**Track the below URL for one-step submission**

<https://juniperpublishers.com/online-submission.php>