

Simulation and Performance Analysis for Non-Hermitian Symmetry DCO-OFDM modulation in 100G-SWDM2 Datacenters Transmission System based OM3/OM4 Fibers

Max Fréjus Owolabi SANYA*, Canisius M. B. CODJIA*, Fifamè Merci-Ange MAGNIDET*, Sabi Yari Moïse BANDIRI**

*(Department of Computer Sciences and Telecommunications, University of Abomey-Calavi, Benin
Email: frejus.sanya@uac.bj, bocacodji@gmail.com, fifame.magnidet@outlook.com)

** (Grupo de Pesquisa em Sistemas de Comunicações Tecnológicas de Geração Futura, UNILAB, Brazil
Email: bandiri@unilab.edu.br)

Abstract:

This paper investigates the performance of Non-Hermitian Symmetry (NHS) Direct-Current biased Optical OFDM (DCO-OFDM) in the context of 100G-SWDM (Short Wavelength Division Multiplexing) datacenters using OM3/OM4 fibers. OFDM is recognized for its robustness against optical fiber link distortion, while NHS exhibits low power consumption, leveraging its half computational complexity compared to Hermitian Symmetry in terms of optical OFDM modulator/demodulator. The study begins with a Bit Error Rate (BER) performance comparison between conventional DCO-OFDM and NRZ-OOK in a 100G-SWDM4 (25 Gb/s x 4) link. Based on the good distance transmission performed by DCO-OFDM, an implementation of NHS DCO-OFDM is realized in a 100G-SWDM2 (50 Gb/s x 2) architecture. The results, obtained through simulation with realistic component parameters, reveal that NHS DCO-OFDM, referred to as (new-DCO), achieves approximately four (04) to five (05) times the distance transmission allowed by NRZ-OOK in a 100G-SWDM4 link, depending on the use of OM3 or OM4 fibers. Additionally, the new-DCO demonstrates promising distance transmission capabilities of 370m for OM3 fiber and 650m for OM4 fiber in the simulated 100G-SWDM2 architecture. Consequently, the new-DCO emerges as a good candidate for datacenter transmission, surpassing current transmission distances demonstrated by SWDM alliance partners.

Keywords —Datacenter, SWDM, NHS DCO-OFDM, NRZ-OOK, OM3/OM4 fiber.

I. INTRODUCTION

Datacenters are intricate infrastructures comprising a network of servers and storage spaces dedicated to the uninterrupted storage, organization, and processing of vast amounts of data belonging to companies. Primarily designed to cater to the escalating computational and data storage requirements of large enterprises, datacenters are faced with time constraints for efficient data processing and management. The proliferation and diversification of connected devices, coupled with escalating data storage needs, contribute to the continuous expansion of bandwidth requirements

within datacenters. As a result, datacenters are perpetually seeking higher bandwidth to cope with the surging demand generated by the emergence of services such as cloud storage, e-services (e-commerce, e-health, e-learning, etc.), Internet of Things (IoT), streaming videos, voice over IP, social networks, and more [1]. The growth of these services leads to a rapid increase in data traffic within datacenters. The core network of these transmission systems is the intra-datacenter information exchange, serving as the storage and processing center for vast volumes of data that fuel all digital uses. It facilitates the transmission of data within the inter-datacenter

network segment and towards end users. Examining the distribution of total traffic related to datacenters, intra-datacenter traffic dominates, accounting for 71.5 percent of the overall traffic. Furthermore, 14.9 percent of the traffic travels from datacenters to end users, and 13.6 percent is exchanged between datacenters. The substantial percentage of intra-datacenter traffic underscores the extensive data exchange occurring between different servers or storage units within datacenter networks. In its forecast covering the period 2016-2021, Cisco, in its white paper on the global index of cloud services, reported a consistent increase in the global IP traffic of datacenters [2].

The interconnections among different servers within a datacenter must be scalable, providing exceptionally high data rates to enhance processing speed and resource accessibility. In response to this demand, telecom operators are compelled to increase the capacity of their infrastructures by migrating to higher throughput while minimizing associated costs. Opting for optical fiber communication systems has proved decisive in achieving these elevated data rates. Based on standards like Gigabit Ethernet (GE), such as IEEE 40GBASE-SR4 (2010), IEEE 100GBASE-SR10 (2010), and 100GBASE-SR4 (2015), optical interfaces for 10 GE and 25 GE have facilitated the deployment of parallel optical links with data rates of 40 Gb/s (4 x 10 Gb/s, using four fiber pairs), 100 Gb/s (10 x 10 Gb/s, using ten fiber pairs), and 100 Gb/s (4 x 25 Gb/s, using four fiber pairs) within datacenters. These deployed optical links typically employ Vertical Cavity Surface Emitting Laser (VCSEL) sources coupled to multimode OM3/OM4 fibers, operating within the 850-950 nm wavelength range [3], [4]. Non-Return to Zero-On/Off Keying (NRZ-OOK) modulation is often implemented in these optical links. However, with the adoption of the IEEE 50GBASE-SR standard, the use of advanced modulation formats, such as Pulse Amplitude Modulation (4-PAM), has been recommended [5] to achieve data rates exceeding 40 Gb/s (≥ 40 Gb/s). Thus, instead of using four parallel 25 Gb/s (4x25 Gb/s) links to achieve a total throughput of 100 Gb/s, it becomes feasible to consider only two 50 Gb/s channels (2x50 Gb/s).

Datacenters face challenges in cable management and maintenance, particularly as the number of cables increases, becoming more cumbersome with each upgrade to higher throughput [6]. In an effort to streamline cable deployment, enhance manageability and maintenance efficiency, and minimize infrastructure deployment costs, engineers have explored the concept of resource pooling. The solution identified for datacenters is the Shortwave Wavelength Division Multiplexing (SWDM) technique, which is endorsed and standardized by the Multi-Source Agreement for SWDM (MSA-SWDM) consortium. MSA Consortium comprises various suppliers of transceiver modules, optical fibers, and Operating Equipment Manufacturers (OEM), including Huawei, Dell, Finisar, Cisco, among others [7], [8]. Wavelengths employed in SWDM are chosen within the 850 nm to 940 nm range, featuring a 30 nm inter-channel spacing, aligning with MSA-SWDM specifications.

With the adoption of SWDM, achieving a throughput of 40 Gb/s (or 100 Gb/s) is made possible through a serial link by multiplexing four (04) wavelengths of 10 Gb/s (or 25 Gb/s) on a single fiber pair. This configuration is denoted as 40G-SWDM4 (i.e., $4\lambda \times 10$ Gb/s) or 100G-SWDM4 (i.e., $4\lambda \times 25$ Gb/s) depending on the specific context. MSA-SWDM Specify transmission distances achievable on, respectively OM3, OM4 and even OM5 fibers for 40G-SWDM4 and 100G-SWDM4 systems [5], [9], [10].

Incorporating the 50 Gigabit Ethernet standard specification proves to be a valuable asset in maximizing the potential of SWDM, facilitating the attainment of 100 Gb/s. Additionally, there is an emerging interest in the simultaneous multiplexing of two (02) channels, each carrying 50 Gb/s wavelengths (i.e., $2\lambda \times 50$ Gb/s) on a single fiber. This innovative approach, termed SWDM2, is currently in the standardization draft phase. It not only optimizes wavelength utilization but also enhances the efficiency of deployed fibers. This strategy, coupled with an advanced modulation format, presents itself as an inventive and promising solution for enhancing throughput in future generations of optical transmission systems within datacenters. To achieve this goal with

Intensity Modulation/Direct Detection (IM/DD) transceivers, different modulation schemes have been proposed in the literature, starting from the simple NRZ-OOK [11] to those demonstrating optimal spectral efficiency. Transfer rates of 160 Gb/s per wavelength have been successfully demonstrated through Discrete Multitone Modulation (DMT). Additionally, duobinary 4-PAM, multiCAP (Carrierless Amplitude/Phase modulation), 4-PAM, and 8-PAM (Pulse Amplitude Modulation, levels 4 or 8) have showcased transfer rates of 62.5 Gb/s, 148 Gb/s, 112.5 Gb/s, and 90 Gb/s, respectively [12], [13]. The integration of modulation and channel equalization with SWDM has led to the achievement of 200 m OM4 links, operating at 42.5 Gb/s and 48.8 Gb/s per wavelength, as reported in literature [14]-[16]. Studies employing Orthogonal Frequency Division Multiplexing (OFDM) have demonstrated a feasible transmission distance of 100 m over multimode fiber for 100 Gb/s throughput [17,18]. In a recent experiment, Finisar Corporation showcased the capabilities of a 100G-SWDM4 link, achieving respectively, a reach of 200 m, 300 m and 400 m over respectively OM3, OM4 and OM5 [19]. However, detailed technical specifications related to the proposed transmission systems remain proprietary. A recent investigation of Asymmetrically Clipped Optical-OFDM (ACO-OFDM) and Direct Current biased Optical-OFDM (DCO-OFDM) using Quadrature Amplitude Modulation (QAM) revealed promising results. Specifically, distances of 410 m (OM3) and 600 m (OM4) were achieved with 100G-SWDM4 for ACO-OFDM, while DCO-OFDM demonstrated ranges of 440 m (OM3) and 685 m (OM4) [20]. These recent advancements in OFDM on multimode fibers coupled with Vertical-Cavity Surface-Emitting Lasers (VCSELs) reveals its potential as a promising solution for SWDM transmissions in datacenters. To the best of our knowledge, no study has comprehensively explored the performance over OM3, OM4, or OM5 fibers for a 100G-SWDM4 and 100G-SWDM2 link employing the Non-Hermitian Symmetry DCO-OFDM [21], referred here, to as "New-DCO". Hence, this study aims to address this gap and evaluate the potential of the New-DCO technique.

The structure of the paper is organized as follows: Section II starts with an overview of DCO-OFDM implementation, providing insights into the materials and methods employed, along with a concise depiction of the Non-Hermitian Symmetry concept applied to DCO-OFDM. Following this, Section III presents the obtained results and engages in a discussion thereof. Finally, we conclude in Section IV.

II. MATERIALS AND METHODS

In this section, we start by providing an overview of DCO-OFDM technique.

A. DCO-OFDM technique

Orthogonal Frequency Division Multiplexing (OFDM) is a multi-carrier modulation technique that transmits information through multiple subcarriers. The fundamental principle involves transmitting symbols in parallel across distinct subcarriers using the Inverse Fast Fourier Transform (IFFT). As the resulting OFDM signal becomes complex and bipolar post IFFT, a transformation is necessary to render it real and positive for optical transmission. Achieving a real signal involves applying Hermitian Symmetry to the QAM symbols prior to entering the IFFT block [21], [22]. DCO-OFDM technique extends this approach by introducing a suitable DC-bias to the real and bipolar signal at the output of the IFFT block, ensuring its positivity. Despite the inclusion of the DC component, if residual negative peaks persist in the OFDM signal, zero clipping process is employed by setting them to zero values. Fig. 1 illustrates the block diagram of a DCO-OFDM system link. In the transmitter section, a binary frame undergoes modulation, mapping it into Quadrature and Amplitude Modulation (QAM) symbols.

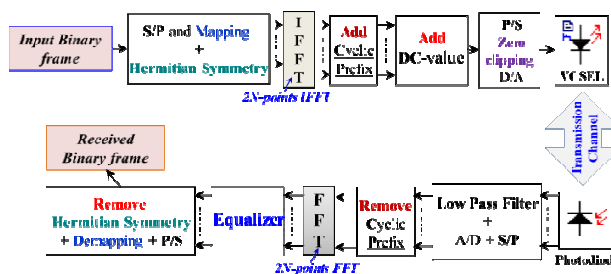

Fig.1 Block diagram of a DCO-OFDM system

Then, these symbols are constrained to exhibit Hermitian Symmetry at the input of a $2N$ -IFFT block, as:

$$X(2N - k) = X^*(k), \quad k = 1, 2, \dots, N - 1 \quad (1)$$

Where $X(0) = X(N) = 0$, and $X^*(k)$ is the complex conjugate of $X(k)$. At the output of the IFFT block, cyclic prefix is added to each resulting OFDM symbol and a suitable DC-bias value is added to it before zero-clipping. After that, the obtained DCO-OFDM signal, directly modulates an optical source (here, a VCSEL) before being propagated through an optical fiber channel. At the receiver side, the detected electrical signal obtained after photodiode, undergoes the reverse process with a few exceptions. Cyclic prefix is removed, FFT transform is applied and then, the signal is equalized. Finally, Hermitian Symmetry is removed before QAM demapping followed by binary frame recovering.

B. Non-Hermitian DCO-OFDM technique

The Non-Hermitian DCO-OFDM approach involves generating a real OFDM signal without imposing the constraint of Hermitian Symmetry on the QAM symbols at the IFFT input [23]. In the NHS DCO-OFDM, symbols $X(k)$ directly modulate an IFFT/FFT block size of N , as depicted in Fig. 2(a). This results in a time complex OFDM signal, as illustrated in equation (2) and expressed in (3), taking into account $X(0) = 0$ to prevent any DC shift:

$$x(n) = \sum_{k=0}^{N-1} X(k) \exp\left(j2\pi \frac{kn}{N}\right), \quad (2)$$

$$x(n) = x_R(n) + jx_I(n), \quad n = 0, 1, \dots, N - 1 \quad (3)$$

$x_R(n)$ and $x_I(n)$ are respectively the real and imaginary parts of signal $x(n)$. The transmitted real signal is derived by appending a Cyclic Prefix (CP) at the IFFT output and then concatenating, in the time domain, both the real and imaginary parts of the x_{CP} signal. It is important to note that each $x_{CP}(n')$ has length of $N' = N + N_{CP}$ due to the added CP samples. To eliminate negative values, a proper DC-bias is added to the resulting x_{CP} , following the

conventional approach in a DCO-OFDM transmitter.

In the NHS DCO-OFDM receiver, as illustrated in Fig. 2(b), each set of $2N'$ samples in the received $y(n')$ signal is decomposed into two distinct signal components.

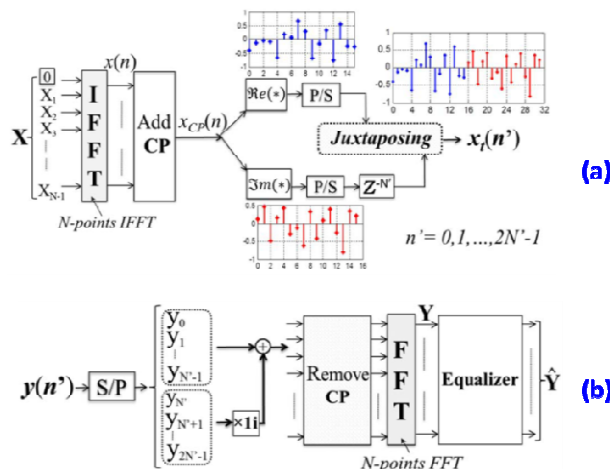

Fig.2 Diagram blocks of New-DCO-OFDM transmission system

The first N' samples and the last N' are considered as the real and imaginary parts, respectively of a signal $z_{CP}(n')$. Then, this $z_{CP}(n')$ signal is demodulated by an N -FFT block after CP removal. Equalization is conducted to offset channel distortion, followed by QAM demodulation to recover the data. Furthermore, since the IFFT/FFT block size is halved in NHS DCO-OFDM, there is a corresponding reduction in computational complexity per bit, involving the number of operations in terms of multiplications and additions per second, by at least half [24]. Additionally, considering that the length of the OFDM symbol is doubled while the IFFT/FFT size is reduced by half, the spectral efficiency of NHS DCO-OFDM remains consistent with that of conventional DCO-OFDM. For simplicity, throughout the paper, we use the abbreviations "DCO" and "new-DCO" for "DCO-OFDM" and "NHS DCO-OFDM" respectively.

C. Simulations Setup

In this subsection, we initiate the study with the simulation of a 100G-SWDM4 (25 Gb/s x 4 λ) system link, as depicted in Fig. 3. Both NRZ-OOK

and OFDM (DCO and new-DCO) techniques are implemented using MATLAB software.

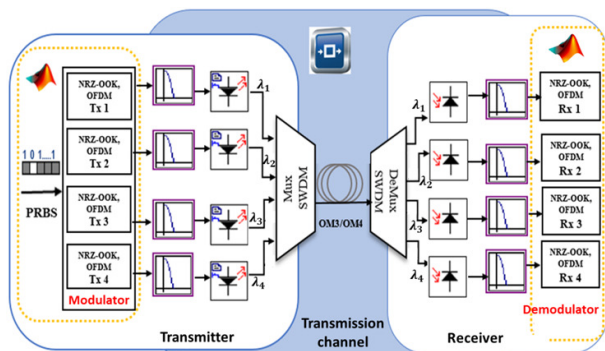

Fig.3 Diagram blocks of the simulated 100G-SWDM4 link

The transmission channel is constructed using Optisystem15 software and modeled with VCSEL sources, SWDM Multiplexer and De-multiplexer, Multimode Fiber OM3/OM4, and PIN photodiodes with transimpedance Amplifier (TIA). The simulated parameters are specified in Table 1 and Table 2. VCSEL sources are cost-effective solutions widely deployed in optical links within datacenters due to their ease of coupling with multimode fibers and low energy consumption [25]. In the simulated SWDM4 link, four (04) VCSELs at wavelengths of 850 nm, 880 nm, 910 nm and 940 nm are SWDM multiplexed [5]. Each VCSEL is directly modulated by an electrical signal (NRZ-OOK or OFDM) provided by the Tx modulator block.

TABLE I
SIMULATION PARAMETERS FOR THE LASER SOURCE, THE RECEIVER AND SWDM MUX/DEMUX [5], [27], [28]

Parameters	Values
VCSEL	
Linewidth	10 MHz
Adiabatic factor	10000 1/W.s
Alpha Chirp	3.7
Slope efficiency	0.54 mW/mA
Threshold current	0.5 mA
Bias current	6 mA
Laser transconductance	0.02 A/V
RIN	-140 dB/Hz
Bandwidth	21 GHz
Low-pass filter type	Bessel
Low-pass filter order	4
Attenuation	2.3 dB/km
Chromatic dispersion	-100 ps/nm.km
Receiver (PIN+TIA)	
Responsivity	0.45 A/W
Dark current	50 nA

TIA impedance	56.5 Ω
Low-pass filter type	Bessel
Low-pass filter order	4
Bandwidth	25 GHz
Thermal noise	0.121e ⁻²¹ W/Hz
ASE and shot noise	Enabled
SWDM Mux/Demux	
Operating wavelength	850 ~ 940 nm
Inter-channel Spacing	30 nm
Bandwidth	21 nm

TABLE III
SIMULATED CHARACTERISTICS OF THE MULTIMODE OM3 AND OM4 FIBERS

Wavelength	OM3 Modal bandwidth	OM4 Modal bandwidth
850nm	2000 MHz.km	4700 MHz.km
880nm	1750 MHz.km	3300 MHz.km
910nm	1500 MHz.km	2325 MHz.km
940nm	1250 MHz.km	2000 MHz.km

The resulting SWDM multiplexed signal is transmitted through the multimode fiber (OM3 or OM4) and then de-multiplexed into four (04) signals at the receiver. The received optical signals are detected and converted into equivalent electrical signals by some associated receivers, for the equalization and demodulation steps. This process is implemented using MATLAB for NRZ-OOK or OFDM techniques in the Rx block. Then, the Bit Error Rate (BER) is estimated using the Error Vector Magnitude (EVM) method as described in [26]. According to UIT-T G-989.2 recommendation of the International Telecommunication Union (ITU), the BER target is set to 3.8×10^{-3} , considering the use of Forward Error Code (FEC) and equalizer for effective data recovery. The BER performance is analysed as a function of the range for both NRZ-OOK and DCO. Next, a comparative study of the BER as a function of range was carried out between the DCO and new-DCO techniques under identical simulation conditions.

Fig. 4 shows the proposed 100G-SWDM2 (i.e., 50 Gb/s x 2 λ) link. In this configuration, only two (02) VCSELs operating at a bit rate of 50 Gb/s are multiplexed over the multimode fiber (OM3 or OM4). They emit respectively at wavelengths of $\lambda_1 = 850$ nm and $\lambda_2 = 880$ nm. Two (02) photodiodes with their TIAs are employed at the receiver side. The simulation utilizes the parameters outlined in Tables 1 and 2.

III. RESULTS AND DISCUSSION

Given the nearly identical Bit Error Rate (BER) results across all multiplexed wavelengths within the 850 nm optical window, our discussion focuses on the performance obtained at the simulated wavelength of 850 nm

A. Transmission performance in the 100G-SWDM4 system link

Fig.4 shows the variation in BER performance as a function of the range for NRZ-OOK and DCO when simulating the link presented in Fig. 3. The analysis of Fig. 4 reveals that the BER degrades with the increase in fiber distance. This degradation is attributed to the chirp phenomenon of the VCSEL sources combined with the modal dispersion of the multimode fibers [12], [18].

However, utilizing the DCO technique, the performances obtained are almost the same in OM3 as in OM4 up to around 600 m. This can be explained by the fact that the channel exhibits almost the same behavior (or transfer function) for range up to 600 m in both OM3 and OM4 cases.

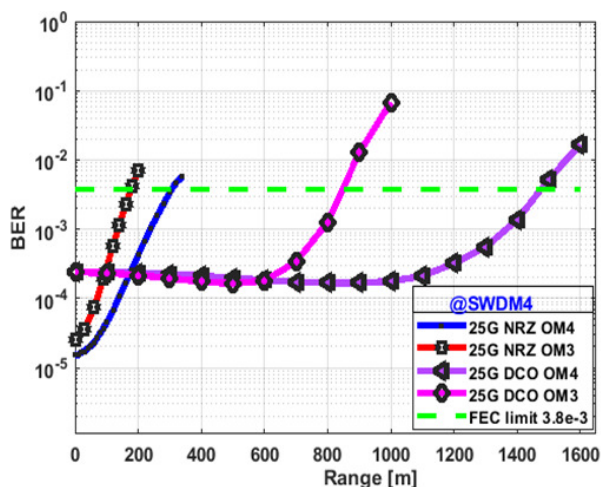

Fig.4 BER = f(Range) of the 100G-SWDM4 link with NRZ-OOK and DCO-OFDM

Moreover, it can be seen that, for a BER target of 3.8×10^{-3} , it is possible to achieve a maximum distance of 180 m of OM3 fiber with NRZ-OOK compared to 850 m with DCO, thus about four (04) times the distance allowed in NRZ-OOK. Similarly, for OM4 fiber, NRZ-OOK achieves a maximum distance of 300 m, while DCO extends this range to 1480 m, indicating a distance gain of approximately

five (05) times that achieved with NRZ-OOK. This superior performance of DCO over NRZ-OOK can be attributed to its robustness against the frequency selectivity of the optical channel [17], coupled with the higher modal bandwidth provided by OM4 fiber in comparison to OM3 fiber (Cf. Table 3).

Fig. 5 presents the BER variation in terms of the range for both DCO and new-DCO under identical conditions. Analysis of Fig. 5 reveals comparable BER performance between the new-DCO and the conventional DCO for all simulated optical multimode fibers (OM3 or OM4). Similar results are observed for ACO-OFDM [23], which can be explained by the fact that, during transmission, any noise distortion is spread over two consecutive blocks rather than one block in the new-DCO. This condition results in the same overall Signal-to-Noise Ratio (SNR) for new-DCO compared to conventional DCO. It can be also observed that for BER value of 3.8×10^{-3} , it is feasible with the simulated parameters to achieve a distance of approximately 850 m over OM3 fiber and 1480 m over OM4 fiber, nearly double of the distance allowed with OM3 fiber.

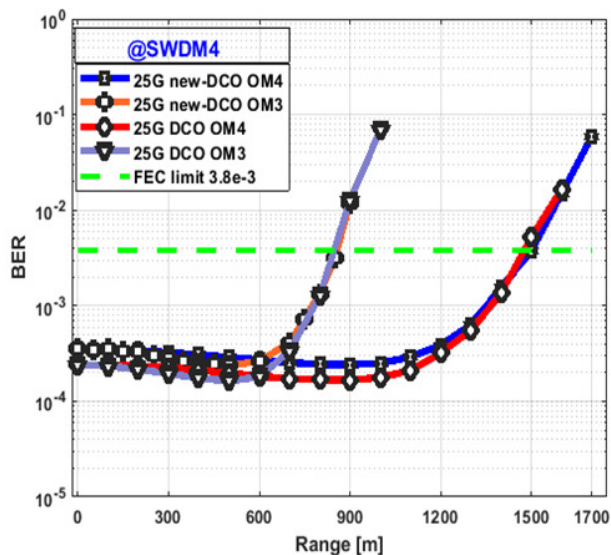

Fig.5 BER = f(Range) of the 100G-SWDM4 link with new-DCO and conventional DCO-OFDM

Moreover, compared to the specifications provided in Table 1 and Table 2, by the Optical Fiber Solutions (OFS), the simulated new-DCO 100G-SWDM4 show better performance in terms of transmission distance. This seems interesting and

allows us to guide such companies in the manufacturing of new 100G-SWDM4 transceivers. Given the computational complexity reduction by half in new-DCO compared to conventional DCO, along with its similar BER performance, this allows us to propose it as an effective solution to improve the distance in the 100G-SWDM4 context. In the next subsection, we focus on the achieved performance in the 100G-SWDM2 architecture.

B. Transmission performance in the 100G-SWDM2 system link

Fig. 6 shows the BER variation in terms of the range for both DCO and new-DCO in the simulated 100G-SWDM2 link over OM3 and OM4 fibers.

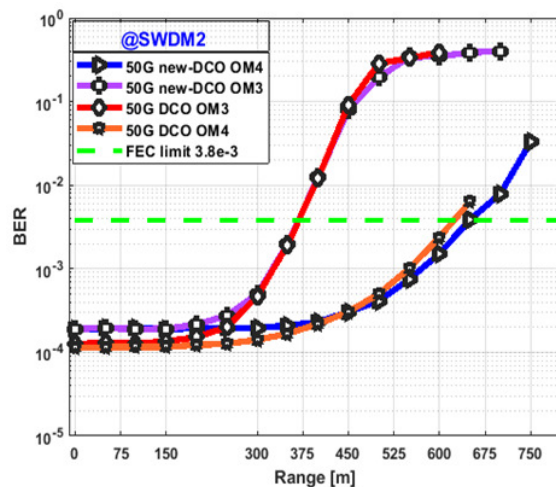

Fig.6 BER = f(Range) of the 100G-SWDM2 link with new-DCO-OFDM and conventional DCO-OFDM

The obtained results align with our previous findings in the simulated 100G-SWDM4. Thus, for a BER target value of 3.8×10^{-3} , distances of about 370 m for OM3 fiber and 650 m for OM4 fiber can be achieved, nearly doubling that of OM3. Given the comparable curves obtained in new-DCO compared to DCO in this architecture, it can be inferred that new-DCO is a promising candidate for enhancing the transmission distance in 100G-SWDM2 links.

IV. CONCLUSION

The performance analysis of Non-Hermitian Symmetry DCO-OFDM (NHS DCO-OFDM), referred to as “new-DCO” is explored in the context of 100G-SWDM4 and 100G-SWDM2 for

datacenter transmission. After simulation in a 100G-SWDM4 scenario, we demonstrated that it is feasible to reach distances approximately four (04) to five (05) times longer than those achieved with NRZ-OOK using DCO-OFDM.

Furthermore, given the substantial reduction in the computational complexity of NHS DCO-OFDM, along with the potential decrease in energy consumption within datacenters, its implementation in the 100G-SWDM2 scenario enables an extension of the currently proven distances by the SWDM alliance and its partners [5]. Considering these aspects, it can be concluded that NHS DCO-OFDM in SWDM2 represents a promising approach for achieving high data rates in datacenter transmission, potentially influencing the development of new 100G-SWDM4 and 100G-SWDM2 transceivers by companies.

ACKNOWLEDGMENT

This research is the outcome of a collaborative project between the Polytechnic School of Abomey-Calavi (EPAC) in Benin and the International Integration of the Afro-Brazilian Lusophony - UNILAB in Brazil. We give special thanks to “Optica - formerly OSA”, for their grant supporting the management of the EPAC-UAC Chapter Student.

REFERENCES

- [1] D. Law. (2020) IEEE 802.3TM Industry Connections Ethernet Bandwidth Assessment Part II. [Online]. Available: https://www.ieee802.org/3/ad_hoc/bwa2/BWA2_Report.pdf
- [2] White Paper. (2020) Cisco Annual Internet Report (2018–2023). [Online]. Available: <https://www.cisco.com/c/en/us/solutions/collateral/executive-perspectives/annual-internet-report/white-paper-c11-741490.html>
- [3] F. Chang, *Datacenter Connectivity Technologies: Principles and Practice*, ed., River Publishers, 2018.
- [4] C. M. Agossou, L. Djogbe, F. Sanya, P. Sotindjo, A. Vianou and C. Berthelemot, “Proposal of a VCSEL Datasheet Model for Optical Systems Simulations,” *International Journal of Computer and Information Technology (IJCIT)*, vol. 7(5), pp. 219-223, Nov. 2018.
- [5] J Kamino. (2019) What’s New in Short Reach Optical Links? OFS Multimode Fiber Product Management. [Online]. Available: https://www.bicsi.org/uploadedfiles/PDFs/conference/2019/canada/TS_TUES_4.pdf
- [6] Finisar Corporation. (2015) Finisar demonstrates world’s first 100G QSFP28 SWDM4 module for duplex multimode fiber. [Online]. Available: <https://www.fibre-systems.com/product/finisar-demonstrates-100g-qsfp28-swdm4-module>
- [7] D. Lewis. (2017) SWDM MSA Technical Specifications Rev 1.0.1. 40G SWDM4 MSA Technical Specifications. [Online]. Available at: <https://swdm.org/wp-content/uploads/2017/11/40G-SWDM4-MSA-Technical-Spec-1-0-1.pdf>
- [8] D. Lewis. (2017) SWDM MSA Technical Specifications Rev 1.0.1. 100G SWDM4 MSA Technical Specifications. [Online]. Available at:

- <https://www.swdm.org/wp-content/uploads/2017/11/100G-SWDM4-MSA-Technical-Spec-1-0-1.pdf>
- [9] A. A. Correa. (2016) WideCap-OM4 Multimode Fibre - Fibre Optimized for Multi-Wavelength Systems. [Online]. Available at: <https://www.prysmiangroup.com/staticres/Nexst-2016-2/articles/prysmian-widecap-mm4.html>
- [10] Y. Sun, "Recent advances for high speed short reach optical interconnects for Datacom links," IEEE CPMT Symposium Japan (ICSJ), Kyoto, Japan, pp. 63-65, 2017.
- [11] W. Hartmann, et al., "100 Gbit/s OOK using a silicon-organic hybrid (SOH) modulator," *European Conference on Optical Communication (ECOC)*, Valencia, Spain, pp. 1-3, 2015.
- [12] S. K. Pavan, J. Lavrencik and S. E. Ralph, "VCSEL-Based PAM-4 Links up to 62 Gbit/s Over OM3, OM4, and WB-MMF: Performance Comparison at 850 nm and 1050 nm," in *Journal of Lightwave Technology*, vol. 35, no. 9, pp. 1614-1623, May 2017.
- [13] IEEE Standard for Ethernet - Amendment 3: Physical Layer Specifications and Management Parameters for 100 Gb/s, 200 Gb/s, and 400 Gb/s Operation over Optical Fiber using 100 Gb/s Signaling. IEEE Std 802.3db-2022 (Amendment to IEEE Std 802.3-2022 as amended by IEEE Std 802.3dd-2022 and IEEE Std 802.3cs-2022), IEEE 802.3db-2022, 2022.
- [14] Y. Sun et al., "51.56 Gb/s SWDM PAM4 transmission over next generation wide band multimode optical fiber," *Optical Fiber Communications Conference and Exhibition (OFC)*, Anaheim, CA, USA, pp. 1-3, 2016.
- [15] S. M. R. Motaghianezam et al., "180 Gbps PAM4 VCSEL transmission over 300m wideband OM4 fibre," *Optical Fiber Communications Conference and Exhibition (OFC)*, Anaheim, CA, USA, pp. 1-3, 2016.
- [16] R. Motaghian and C. Kocot, "104 Gb/s PAM4 transmission over OM3 and OM4 fibers using 850 and 880 nm VCSELs," *Proceedings of the Conference on Lasers and Electro-Optics (CLEO)*, San Jose, CA, USA, p. 1-2, 2016.
- [17] C. -Y. Huang et al., "Comparison of High-Speed PAM4 and QAM-OFDM Data Transmission Using Single-Mode VCSEL in OM5 and OM4 MMF Links," in *IEEE Journal of Selected Topics in Quantum Electronics*, vol. 26, no. 4, pp. 1-10, July-Aug. 2020.
- [18] P. Torres-Ferrera et al., "Statistical Analysis of 100 Gbps per Wavelength SWDM VCSEL-MMF Data Center Links on a Large Set of OM3 and OM4 Fibers," in *Journal of Lightwave Technology*, vol. 40, no. 4, pp. 1018-1026, 15 Feb. 15, 2022, <https://doi.org/10.1109/JLT.2021.3129455>.
- [19] SWDM. (2018) Cost-effective 40G/100G Data Center Upgrades. [Online]. Available: <https://www.digikey.com/Site/Global/Layouts/DownloadPdf.ashx?pdfUrl=B49792F607F6416CBEE7EC8B53A25122>
- [20] C. M. M. Agossou, L. Djogbe, M. F. O. Sanya, P. Sotindjo, A. Vianou and C. Aupetit-Berthelemot, "Extended reach NRZ-OOK data transmission for 40G/60G/100G SWDM4 systems over multimode OM3/OM4 fibers," *IEEE International Black Sea Conference on Communications and Networking (BlackSeaCom)*, Sofia, Bulgaria, 2022, pp. 310-315.
- [21] W. -W. Hu, "An Energy-Efficient ADO-OFDM System for Optical Wireless Communication," in *IEEE Photonics Journal*, vol. 15, no. 6, pp. 1-9, Dec. 2023.
- [22] A Rignon and A Ovsyannikova, "Performance Analysis of DCO-OFDM, ACO-OFDM and ADO-OFDM Under the Influence of Optical Effects," in *Proceedings of the International Conference on Electrical Engineering and Photonics, EExPolytech, ST PETERSBURG, Russian Federation*, pp. 222-225, 2023.
- [23] F. Barrami, Y. Le Guennec, E. Novakov, J. -M. Duchamp and P. Busson, "A novel FFT/IFFT size efficient technique to generate real time optical OFDM signals compatible with IM/DD systems," *European Microwave Conference*, Nuremberg, Germany, pp. 1247-1250, 2013.
- [24] M. F. Sanya, L. Djogbe, A. Vianou and C. Aupetit-Berthelemot, "DC-biased optical OFDM for IM/DD passive optical network systems," in *Journal of Optical Communications and Networking*, vol. 7, no. 4, pp. 205-214, April 2015.
- [25] M. Agustin, et al., "50 Gb/s NRZ and 4-PAM data transmission over OM5 fiber in the SWDM wavelength range," in *Proc. SPIE 10552*, *Vertical-Cavity Surface-Emitting Lasers XXII*, 1055202, 19 February 2018
- [26] M. Seimetz, *High-order modulation for optical fiber transmission*: Springer, ed., 2009.
- [27] Vertically Integrated System. Up to 50 Gb/s PAM-4 VCSEL Multi-Mode Fiber-Coupled Module (850 nm).[Online]. Available at: <https://v-i-systems.com/wp-content/uploads/2019/02/VIS-Datasheet-VM50-850M-module.pdf>
- [28] THORLABS. DX25C and DX25D Series: 25GHz Photodetectors. [Online]. Available at: <https://www.meetoptics.com/detection-devices/photodiodes-sensors-and-modules/single-mode-ultrafast-photodetector-module/s/thorlabs/p/DX25HF>