

Technical-Economic Analysis of Photovoltaic and Small-Scale Wind Turbine Hybrid System for Rural Health Centers: A Case Study in South Benin

Vodounnou Edmond Claude^{1,*}, Gbado Douala Cresus Pierre¹, Ahouannou Clement¹, Degan Gerard¹, Vianou Antoine²

¹Laboratory of Energetics and Applied Mechanics, Polytechnic School of Abomey-Calavi, University of Abomey Calavi, Cotonou, Republic of Benin

²Laboratory of Materials Thermophysical Characterization and Energy Appropriation (Labo-CTMAE), Calavi Polytechnic School, University of Abomey-Calavi, Cotonou, Republic of Benin

Email address:

edmonvod01@gmail.com (Vodounnou Edmond Claude)

*Corresponding author

To cite this article:

Vodounnou Edmond Claude, Gbado Douala Cresus Pierre, Ahouannou Clement, Degan Gerard, Vianou Antoine. Technical-Economic Analysis of Photovoltaic and Small-Scale Wind Turbine Hybrid System for Rural Health Centers: A Case Study in South Benin. *American Journal of Energy Engineering*. Vol. 10, No. 4, 2022, pp. 103-115. doi: 10.11648/j.ajee.20221004.13

Received: October 18, 2022; **Accepted:** November 2, 2022; **Published:** November 22, 2022

Abstract: The Republic of Benin, like other West African countries, has a low rate of rural electrification (less than 20%). Therefore, all rural health centers operate without electricity. It is necessary to develop solutions to empower rural health centers. Integrated hybrid renewable energy solutions have demonstrated their ability to provide reliable and cost-effective electricity to health centers. This article is part of a technical and economic study of different solutions of mixed renewable energy systems to meet the needs of rural health centers. To determine the electrical load of the rural health center, we used a method that consists of monitoring the electricity consumption of a standard center for 92 days. Using a power meter data logger, health center consumption was recorded for the entire period. The monitored load of the rural health center consists mainly of lighting and electrical appliances such as the freezer. Consumption is monitored with a five minute time step so the data can be used to generate any level of load profile detail. Then a 15 minute step load profile is generated for each day and the daily profiles are repeated to create a load profile for the whole year by applying a small stochastic variation function. Regarding our results, we noted a technical-economic optimization of a small-scale wind-photovoltaic (PV) battery system with a concern for reliability and a comparison with a grid extension solution. Then, we presented the results of monitoring the load of a rural health center and the results of the extension of the network and the hybrid system. Reliability and cost aspects are analyzed. The results obtained showed that despite the scarcity of wind resources, the complementarity of wind and solar potentials increases the efficiency of the system for a break-even point of 1 km to 5 km for wind-PV-battery systems.

Keywords: Rural Health Care Centres, Energy Load Estimation, Break-Even Distance, Wind-Pv-Battery System, Energy Shortage Probability, Energy Need Estimation

1. Introduction

1.1. Rural Electrification

Access to energy, specifically to electricity is a key component of countries development and population's quality of life improvement. Nowadays almost 12% of the world's population and 22% of the world's rural population still lack

access to electricity. When considering the sub-Saharan Africa, electricity's lack rate reaches 75% of the population [1] representing 85% of the world's total population. In this region, the rural population have no access to modern energy services and more than half billion people are relying directly on traditional and non-sustainable use of biomass for their energy need. By 2030, it's foreseen that population lacking access to electricity around the world will drop by 6%, down

to 1.3 billion whereas in sub-Saharan Africa this number is expected to rise by more than 5%, reaching more than 700 million people due to demographic factors [2].

Many solutions have been proposed to inflect the exponentially growing curve of the electrification's lack rate in rural zones generally and in West-Africa in particular. To deal with rural energy problems many strategies have been proposed in the literacy. There are two main axes of research, proposing alternatives to grid extension for rural electrification:

- 1) Micro-grid electrification with high content of Renewable Energy (RE) which consist in developing new electricity distribution network connecting remote areas with electricity production of electricity based on the renewable energy potentials immediately available in the area. Many techno-economic studies have proved this strategies to need less investment than grid extension [3, 4].
- 2) Hybrid RE systems are considered for area where multiple sources of energy are available. Many studies on sizing, optimization and economic analysis of hybrid systems are available in the literacy and reviews of simulation and analysis method are available [5, 6]. Hybrid systems present advantages of combining multiple systems, improving availability in different seasons and reduce probability of failure of energy delivery system to meet the needs of the area.

The conditions of electricity supply in rural areas are not progressing fast enough. Accelerating modern energy access progression rate in the Sub-Saharan region is a priority concern for both scientific community and decision makers. Many authors have studied renewable energy solutions and many results have proved those alternatives capacity to effectively help meeting the growing energy demand of remote area and in the meantime, contributes to climate protection efforts and reduction of greenhouse gases emission and its consequences [7]. As agreed by many scientists and policy makers, there is an important need of alternative clean energy resource development to meet rural areas need. "This will improve energy security, increase energy access, particularly to remote communities, reduce dependence on grid electricity, increase productivity and contribute to energy diversification and security" [8]. Those studies have been conducted in accordance with local conditions of many developing countries. In each case area climate, RE potential, financial/economic particularities are used to investigate techno-economic feasibility of the proposed systems and their advantage over a grid extension strategy [9].

West-Africa can count on many renewable potential resources to set alternative energy supply for rural areas. The region has a high solar potential, balanced wind resources, geothermal resources and a large amount of hydraulic potentials. But PV systems and PV-WIND systems are the most studied and installed due to the easy access to the resources, the maturity of technologies and local availability of material on markets [10–14]. The wind power is less used as focus is generally placed in areas where high wind

topography is confirmed. But the possibility exists to use wind energy in low wind topography cases also and with Small-scale Wind Turbine (SWT) [15]. The systems studied are generally for micro-grid power generation and in few cases for small standalone systems. In most of the sub-Saharan countries few progress have been made for remote area energy satisfaction due to budget limitation, energy policy modification needs and/or applications, political lack of decision [16]. Consequently, in rural areas, poor energetic conditions have a direct effect on quality of all services which depend on electricity such as communication, administration services, health care, water access, education, etc. It is necessary to develop solutions for community and public services facilities to get quick access to electricity and to create a real impact on population way of life.

1.2. Rural Health Care Empowering Interest

Population's health is an important key of countries development. To reach the Millennium Development Goals (MDGs) a premium concern is improving health care as four of the eight goals are directly related to population wellness – reduce children mortality; improve maternal health; combat HIV malaria and others diseases; eradicated extreme poverty and hunger.

Continuously available and reliable electricity is of first importance for modern health care facilities. Laboratory and diagnostic equipment and material, cold chain and vaccines preservation and night availability of light for emergency case, all depend on reliable electricity [17].

In Sub-Saharan Africa, 75% of health facilities don't have access to reliable electricity. This scarcity results in interruption or impossibility to operate medical devices, spoilage of vaccines and medicines, limited hours of operations and water sanitation and hygiene problems. According to World Bank report, rural health centre benefits directly from access to power by extended operating hours, more presence of workers that are more likely to live in the rural area [18].

As the rural electrification process is not progressing significantly enough, the remaining solution for health care quality improvement by a rapid electrification is the use of Renewable Energy System directly dedicated to each health care facility's need. Small-scale hybrid renewable energy systems can be designed and integrated for best service delivery to health care centres. In 2007 the electrification of 24 villages was achieved with solar energy. In this project, focus was placed on rural health centre and administrative building electrification. But this strategy was abandoned due to insufficient post delivery service, mis-sizing of systems, rapid depletion and rubbery of some installations. Despite this problems, those villages have encountered strong improvement of inhabitant's life and health care quality [19]. There is a crucial need of integration and techno-economic studies of hybrid system for rural Sub-Saharan African area with consideration for reliability necessary for health care centres.

1.3. Objectives of the Study

Sub-Saharan countries failed to accelerate the rural electrification by using renewable energy resources. This study analyses the techno-economic feasibility of direct integration of Small-scale Wind Turbine-PV-battery hybrid systems on rural health care centre facility.

The aim of the present work is to first determine the load of rural health centre based on electricity consumption monitoring.

Secondarily we choose a location with low wind topography and good complementary possibility between solar and wind potential that can be exploited [20].

The study then evaluates the cost of wind-PV-battery system for different level of reliability including estimated reliability from the grid source. This to find out whether the renewable system would be cost effective when compare to grid extension. To end, analysis of break-even distance and reliability analysis will be performed to set domain where each system is the most effective.

2. Method

2.1. Load Profile Determination

To determine the electric load of the rural health centre, we have monitored for 92 days the electricity consumption of a standard centre. The monitored centre has recently been connected to the grid and is located on the edge of the studied area. Using a wattmeter data logger, the consumption of the health centre was recorded for all the period. The monitored rural health centre load essentially consists in lighting and electric appliance such as freezer. No hot water system, ventilation system or cooling are installed on site. The consumption is monitored with a time step of five minute so that the data can be used to generate any level of detail profile of load. For the study a 15 min step load profile is generated for each day and the daily profiles are repeated to make load profile for the whole year by applying a small stochastic variation function.

2.2. Economic Aspects and Optimization

2.2.1. Net Present Cost (NPC)

The net present cost is the present value of installing and operating the system over its lifetime in the project. Its equal to the sum of the total capital cost, the maintenance cost. The net present cost is a parameter of first importance used by many authors in the literature to analyse the feasibility of a given system. It is an important factor of the decision-making process and systems comparison. For this study the net present cost is estimated as follow:

$$NPC(i, N) = \sum_{k=0}^N \frac{R_k}{(1+i)^k} \quad (1)$$

Where:

R_k is the total cost of the year k ,

N the total year of the life cycle study, and

i the annual real interest rate.

For the study a 25 years project life cycle was choose, so R_k is the sum of initial cost, maintenance and replacement cost and operating cost for year k .

The annual real interest rate is one of the parameters needed to calculate the cost of a system over the project lifetime. It is the discount rate which is used to convert between one-time costs and annualized costs. The annual interest rate is calculated as follow:

$$i = \frac{i_0 - f}{1 + f} \quad (2)$$

Where:

i_0 is the nominal or real interest rate, and

f is the annual inflation rate.

For this study, considering the data of the West African central bank, $i_0 = 5.8\%$ and $f = 2.3\%$ was used to fix the real interest rate value to $i = 3.4\%$ [21, 22].

The Levelized Cost of Energy (LCOE) obtained\$ by dividing the total annualized cost of systems by the total useful energy produced through the year, is used for system comparison.

2.2.2. Energy Shortage Probability (ESP)

While modelling the system, it is necessary to have an idea of its reliability. To measure the reliability of the system the Energy Shortage Probability (ESP) can be used [23, 24].

$$ESP_t = \frac{E_{load} - E_{delivered}}{E_{load}} \quad (3)$$

The ESP over a time t is equal to the consumer's energy demand that could not have been supplied divided by the consumer energy demand for that period of time. That period can be an hour, a day, a month or a year. The ESP is computed using the energy balance of the system over the considered period.

2.2.3. Simulation Tool and Systems Optimization

The software TRNSYS was used to process the simulations. TRNSYS is an Object-Oriented Programming tool that is used for transient system simulation. TRNSYS was considered adequate for the simulation in this study, as it offers the possibility to directly simulate many different energetic systems. Due to its object-oriented architecture, it is also possible to change the system's configuration easily.

For this study, the goal of the optimization process is to find the minimum value of cost (NPC) for a predefined value of acceptable failure of the system represent by a set value of energy shortage probability (ESP_c). The optimization problem has been defined as follow:

The objective function represents the criteria to be maximize or minimize. In our study, the objective function considered is the system Net Present Cost (NPC). The goal is to minimize the value of the NPC, and can be explicated as:

$$\min_x NPC(x) = \min_x \{C_I(x) + C_T(x) + C_M(x) + C_R(x)\} \quad (4)$$

Where C_I, C_T, C_M, C_R represent respectively the installation, total capital, maintenance, and replacement costs and

$x = \{N_{PV,p}, N_{BAT,p}, P_{WT}\}$ is the design variable that

controls the value of the objective function. As a 48 V inverter is used, PV panels are mounted by series of three (03) and batteries of 12 V each are mounted by series of four (04). Then the number of parallel PV strings ($N_{PV,p}$), the number of parallel batteries strings ($N_{BAT,p}$) and the wind turbine power (P_{WT}) are the components of the x vector.

$$\begin{cases} C_T(x) = 3N_{PV,p}UC_{PV} + 4N_{BAT,p}UC_{BAT} + P_{WT}UC_{WT} \\ C_R(x) = 4N_{BAT,p}C_{R,BAT,k} + C_{R,Inv,j} \\ k \in \{7,14,21\}; j \in \{10,20\} \end{cases} \quad (5)$$

UC_{PV} , UC_{BAT} , UC_{WT} represent the unit costs of panel, battery and wind power respectively and the constraint represents others condition that should be met by some parameters. The optimization is done under the condition that the ESP of the optimal solution match a set value by the user.

$$\begin{cases} ESP_y(x) = ESP_c \\ SOC_{min} \leq SOC_{BAT} \leq SOC_{max} \\ 1 \leq N_{PV,p} \leq N_{PV,pmax} \\ 1 \leq N_{BAT,p} \leq N_{BAT,pmax}; 0 \leq P_{WT} \leq 20 \end{cases} \quad (6)$$

Where ESP_y is the ESP of the system and ESP_c represents the set goal of energy shortage. The ESP_c value will be set to grid value of ESP (ESP_{grid}) and other inferior values to analysis the supplementary cost of reliability. SOC_{BAT} , SOC_{min} , SOC_{max} represents battery state of charge and its minimum and maximum value.

The algorithm: for the optimization the GenOpt [25] program was coupled with TRNSYS. GenOpt is a java-based program developed for one or multi-dimensional problem which independent variable can be continuous, discrete or both. It includes various optimization algorithms from parametric research to genetic algorithm. So, the particle

swarm optimization (PSO) method was used and the f^* modified function was minimized.

3. Resources and System Component

3.1. Location and Resources

3.1.1. Location

The studied rural zone is located in the south of Benin an 11 million population developing country in west Africa. The remote area located between 6.507710 and 7.166289 latitude and 1.771799 and 2.47454 longitude. It contains numerous small villages and their health care centres.

3.1.2. Solar Radiation and Wind Speed

The monthly average solar radiation and wind speed of the studied case location are shown in Erreur ! Source du renvoi introuvable.. The figure shows that the region has an important resource of solar energy as the average solar have a minimum value of 4.6 kWh/m²/day in August and reaches its maximum of 6.3 kWh/m²/day in March and May. The average for the whole year is about 5.6 kWh/m²/day.

Figure 1 also shows the evolution of wind speed on sites extract from Meteonorm database. The average wind speed is really low with just 6 months with an average speed exceeding the 3 m/s of wind turbine cut in speed. The maximum of monthly average wind speed is about 4.5 m/s. The interest of including slow wind topography resources is the complementarity of wind and solar resources. As shown by the Figure 1 the period of the year where solar radiation reaches the minimum correspond to those where the windspeed is at its peak. This is confirmed by a Pearson correlation obtained between de two profiles values.

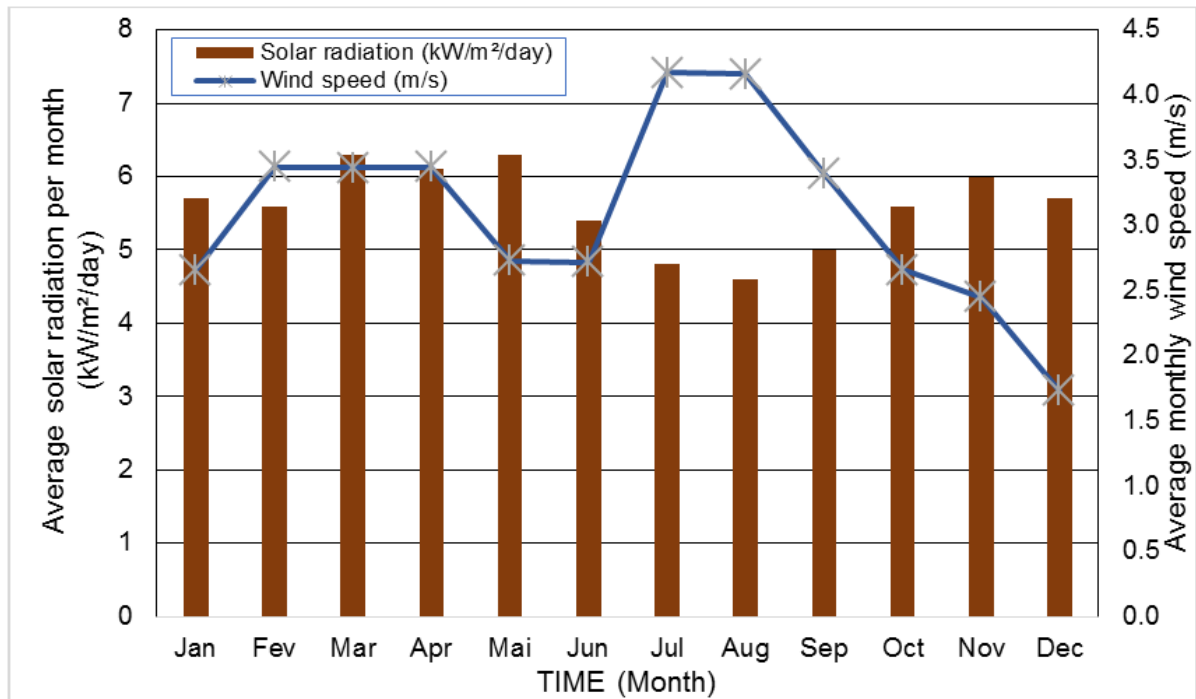

Figure 1. Average solar radiation and wind speed of studied location [26].

3.2. Systems Parameters

3.2.1. Hybrid System Configuration and Parameters

Four mains configurations constitute the of the studied hybrid system: PV panels, wind turbine, inverter and batteries shows the configuration considered, the system architecture and energy flow for the proposed hybrid solar–wind system with battery storage The DC power from the PV panels and wind turbine is converted into AC by the inverter to directly supply the load of the health care centre. If produced energy excess the required load, difference is fed into the battery bank and if not, battery bank releases power to the load via the inverter.

The design specifications and characteristics of all the main part of the studied system are presented in Table 1. For the studies system costs are based on US dollar prices for more simplicity and because many components are not available locally and have to be imported. At the end, all the costs will

be converted to local currency F. CFA (XOF) based on average trade currency of year 2018: US\$1 equivalents to XOF580.

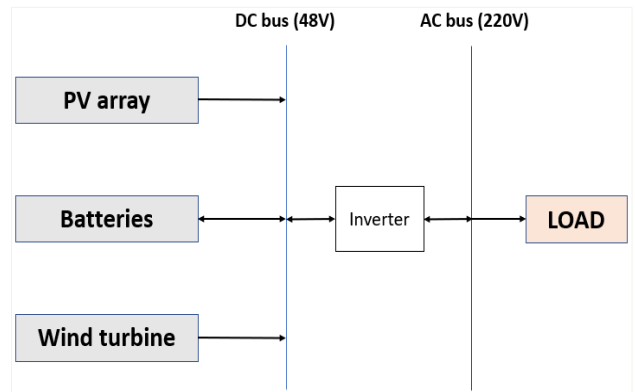

Figure 2. Energy flow for wind/PV/Battery system.

Table 1. Data for hybrid system components.

Description	Data	Description	Data
Inverter		3 -Wind turbines	
Model	Schneider Conext XW PRO 6848	Model	Aleos
Rated power	6,8kw	Rated power	1kw to 20kw
Capital cost	3875\$	Capital cost	1.2\$/W
Replacement cost	3875\$	Installation cost	3500\$
Operating and maintenance cost	1%	Replacement cost	1.\$/W
Life time	10 years	Operating and maintenance cost	3%
Conversion efficiency	95%	Life time	25 years
PV modules		4-Battery	
Model	JKM270PP-60	Model	Full river DC85
Power	270W	Capacity	85Ah
Capital cost	140\$	Capital cost	260\$
Replacement cost	140\$	Voltage	12V
Operating and maintenance cost	1%	Replacement cost	225\$
Life time	25 years	Operating and maintenance cost	3%
		Life time	7 years

3.2.2. Grid Extension

The grid extension is the basis option used as comparison point for hybrid stand-alone systems. At the present time, the parameters of grid extension are listed in Table 2. To determine performance of the Grid, a simulation is performed with monitored data with inclusion of shortage observed on the grid. The same extrapolation is made to set up all year data of power blackout periods.

installed a power meter datalogger on the electrical circuit of health care centre. With the power meter we recorded the consumption of the centre, the power delivered from the grid. We set the recording step to every five minutes (05 min). The monitoring was done for six period of 15 days. The Figure 3 shows the evolution of electric demand for three different days of the monitoring. The profile consists in a constant demand of about 1kw and a peak or two of 3kw and 6 kW appearing randomly during the day.

4. Results and Discussions

4.1. Electric Load

To evaluate rural health centre electric load, we have monitored a rural centre located on the edge of our targeted geographical area. This rural centre provides services to a population of about 7000 people living in the surrounding, have personnel of 8 peoples and consist in a clinic, a maternity house and personnel housing. To monitor the centre, we

Table 2. Grid extension cost parameters.

Description	Data
Grid extension cost	\$25860 /km (15 million XOF)
Grid connexion cost	\$431 (250 000XF)
Grid power cost	\$0,198 /kWh (115 XOF)

To build the year load, one of the 92 days measured profiles was randomly selected to represent each days of the year. The eleven first days of the obtained profiled are represented on Figure 4.

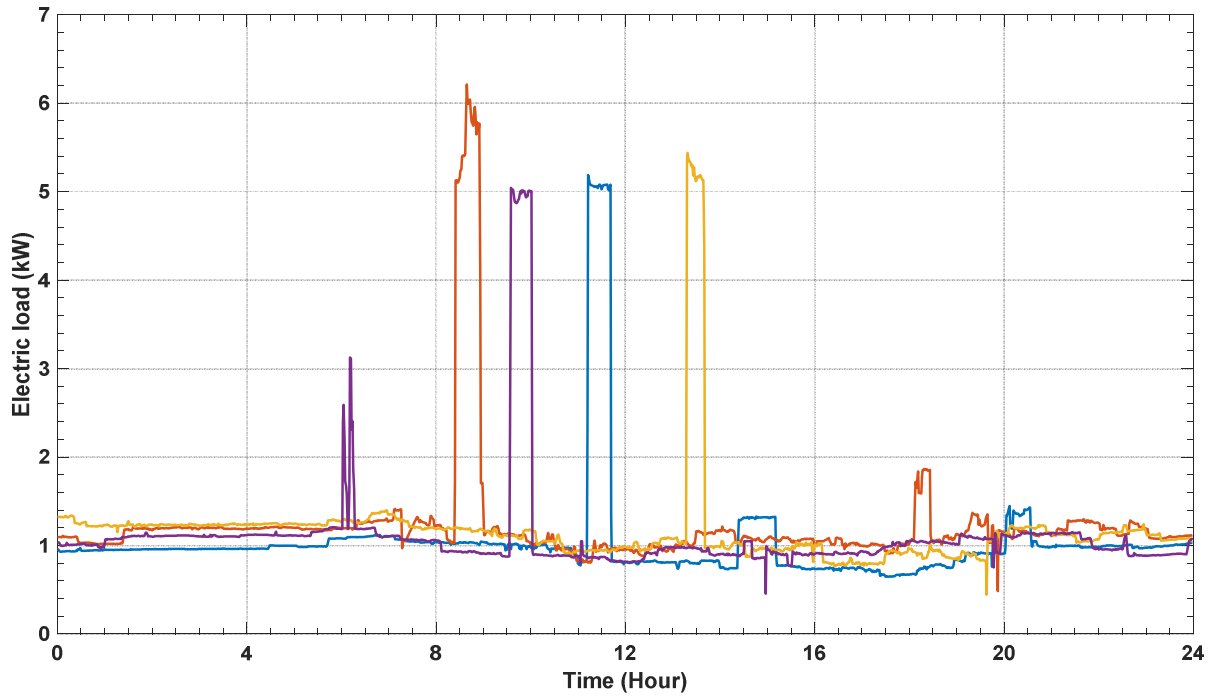

Figure 3. Daily electric consumption profiles recorded on a health care center.

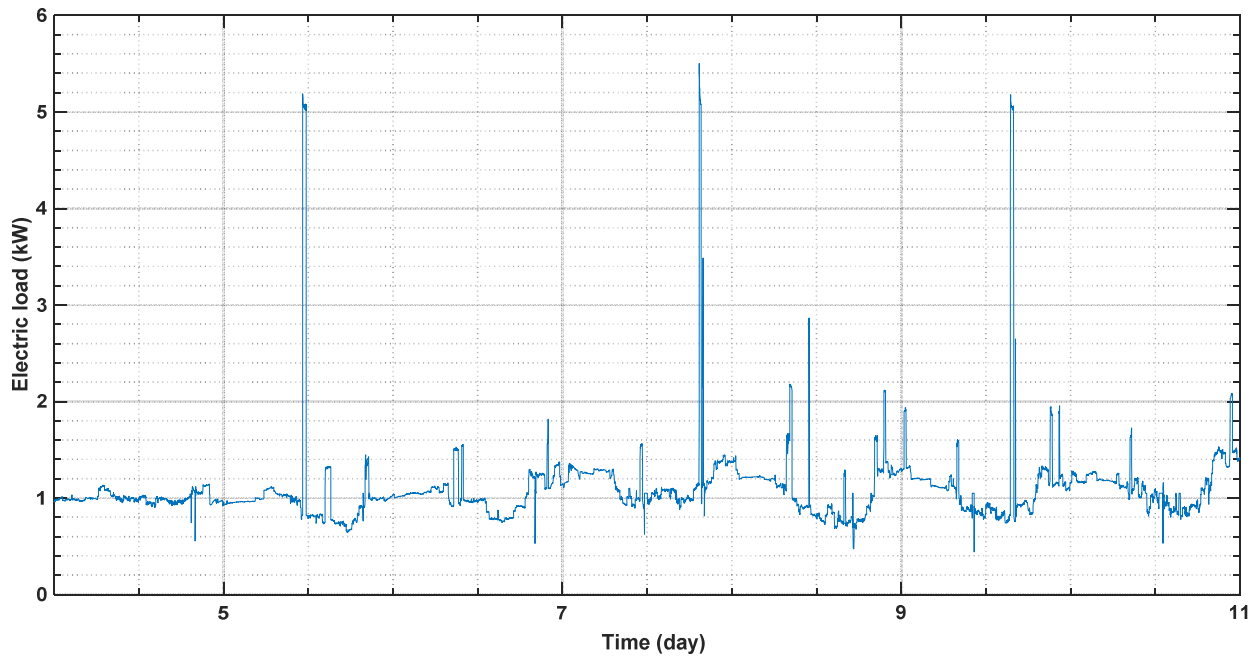

Figure 4. Electrical load of rural health center.

4.2. Grid Extension

As result of grid simulation, the Figure 5 shows the monthly load and the part of it delivered by the grid. The multiple outage that occur on the line during the year result in an ESP of 12.2%. It can be observed that the energy shortage of every month is almost the same. The electricity shortage on the grid does not depend on seasonal variation as the main reason of is the random failure due to lack of maintenance.

For the cost we obtained a life cost of 28668\$ (16,627

million FCFA). This cost represented a levelized cost of 0.135 \$/kWh (78 FCFA/kWh). Depending on the distance between the Health centre and the grid connection point, the life cost of the grid can be obtained by equation:

$$NPC_{Grid} = 26\,668 + 25860 * D \tag{7}$$

$$LCOE_{Grid} = 0.135 + 0.121 * D \tag{8}$$

Where NPC_{Grid} is the life cost of grid connection, $LCOE_{Grid}$ it levelized cost and D the distance of grid extension?

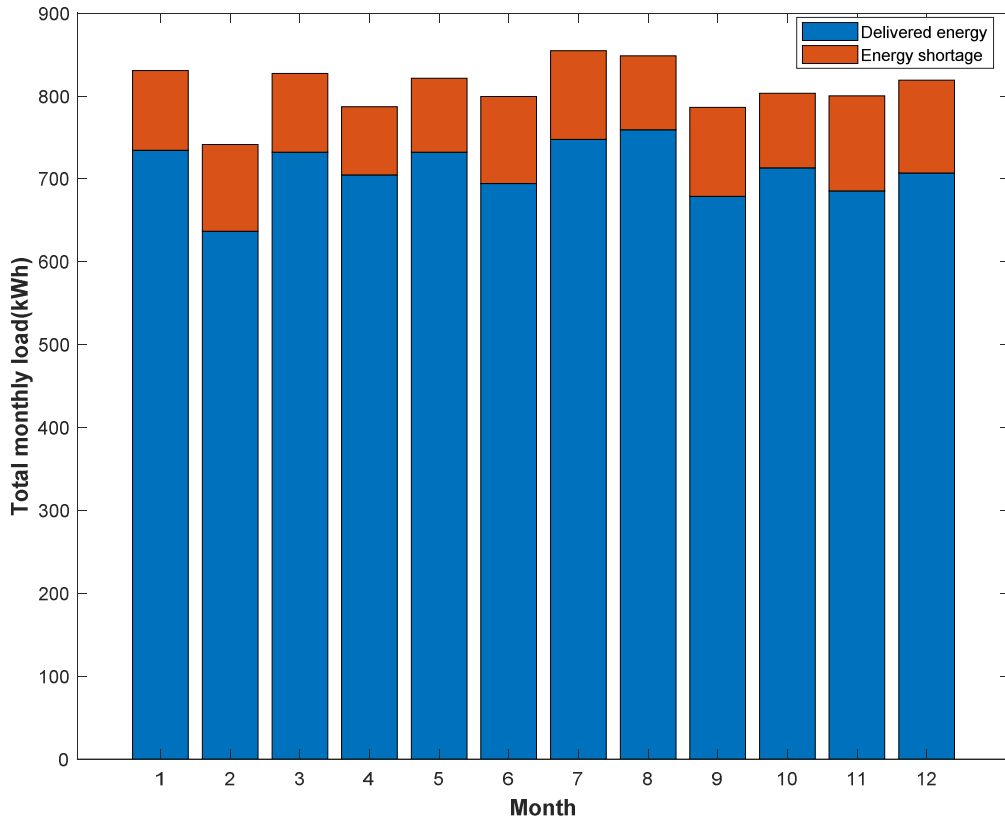

Figure 5. Simulation results of grid performance.

4.3. WIND/PV System with Grid ESP

Considering load and weather data detailed previously, optimization process run for an objective value of ESP_c equal to the grid value ($ESP_{Grid0} = 0.12$). In that condition a net present cost of 86521\$ (50.18 million FCFA). This is obtained by combining 8.8kW PV panels, 20 kW wind turbine

and 8kAh batteries capacity. This capacity of battery represents 3.5 days autonomy considering the average electricity consumption of the rural health care centre. The Figure 6 shows the evolution of the modified cost function f^* during the evolution of the optimization. The PSO algorithm proposed a really fast convergence speed.

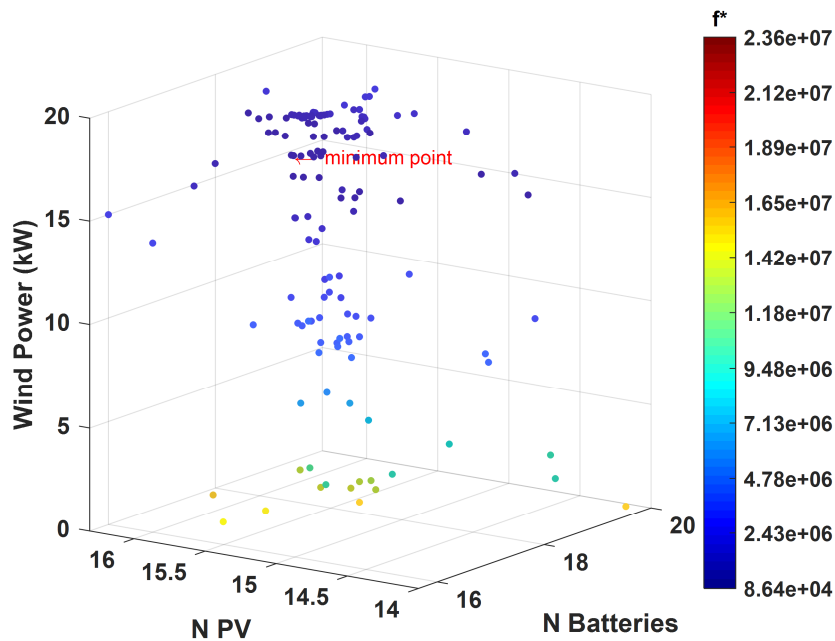

Figure 6. Evolution of function objective during the optimisation.

The Figure 7 shows the monthly repartition of delivered load for ESP corresponding to grid ESP (0.12). The months 1, 5, 6 and 12 are the months with the highest energy shortage. They correspond to the months where the cumulative value solar and wind resources are minimal.

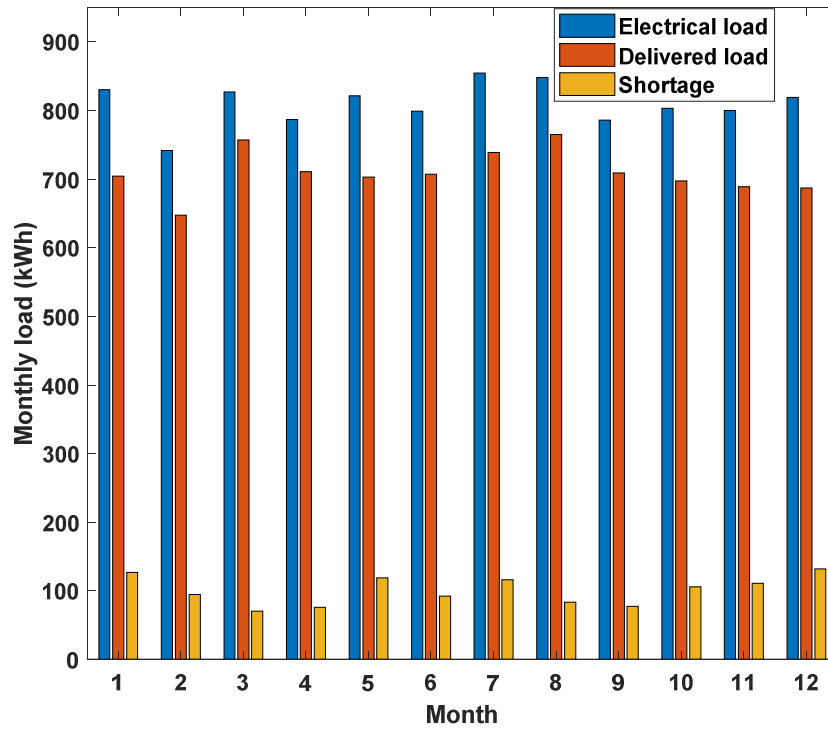

Figure 7. Monthly delivered load and shortage from wind-PV-battery system.

On the opposite side, the month where wind resources are maximum are characterized by the lowest level of shortage. Confirming that despite the weakness of the wind resources, it still can be used to achieve better reliability at minimum cost. This is made possible since the price of small-scaled wind turbine have drastically decrease during the past decade. So instead of highly increasing the amount of batteries to cover the seasonal low quantity of solar radiation available, the wind resource can be used to increase reliability. The break-even distance in this configuration is estimated to 2.4km. So, for rural health centre more than 2.4 km far from the grid. It is better to use the hybrid system than to provide electricity to the centre.

4.4. WIND/PV System with Other Level of Reliability

The same optimization process has been conducted for different other value of ESP. First, we noticed that for any targeted reliability the optimum set of the hybrid system supposed the use of a wind turbine, confirming that it is cost efficient to use wind resources The Table 3 shows a summary of different optimum points determined and the composition of the hybrid system for each point. In parallel it shows the cost and break-even distance for each point. Depending on the objective value set for shortage probability (ESP_c) the break-even distance ranges from 1.9 to 5 km.

Table 3. Optimum calculated points and characteristics.

ESP	PV Power (Wc)	Batteries Capacity (Ah)	Turbine Power (kW)	NPC (USD \$)
0.15	8740	8050	19	86521
0.12	7360	12075	16	91125
0.1	12650	8740	19	91800
0.075	13570	11960	9	92728
0.05	12995	15065	8	99147
0.025	16560	12765	17	107302
0.01	23115	14260	16	113560
0.001	40365	23000	8	151738

This distance is small considering how far from the grid are from most of the health care in that area. As it can be expected the overall cost increased with reliability.

In Figure 8 the distribution of monthly ESP is shown for each calculated point. It can be noticed that the variation of

ESP during the year follow the same pattern. It suggests that this pattern of monthly distribution of the shortage is directly related to the constant of the study: solar and wind resources variation and load pattern.

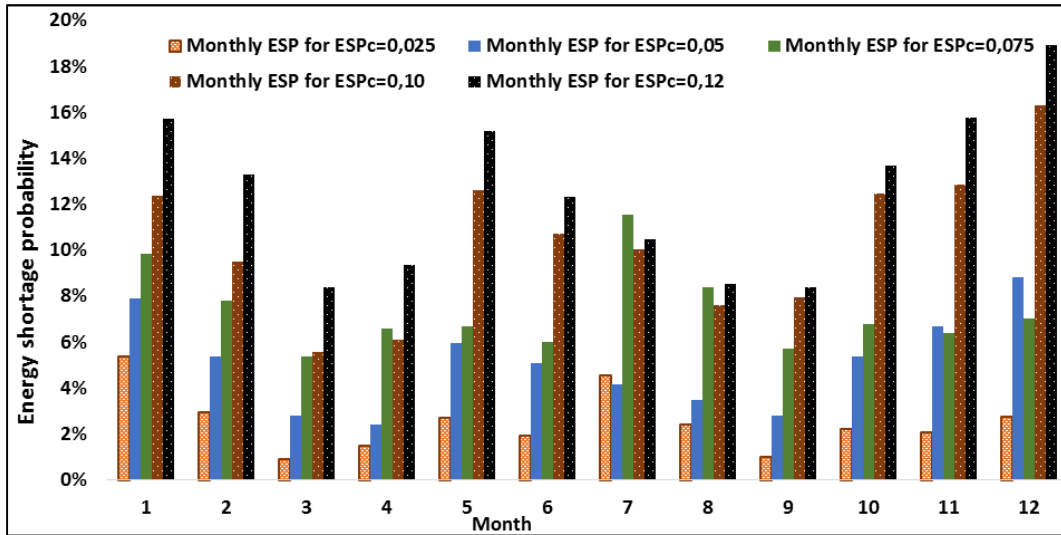

Figure 8. Evolution of monthly ESP for various optimal system with different ESP.

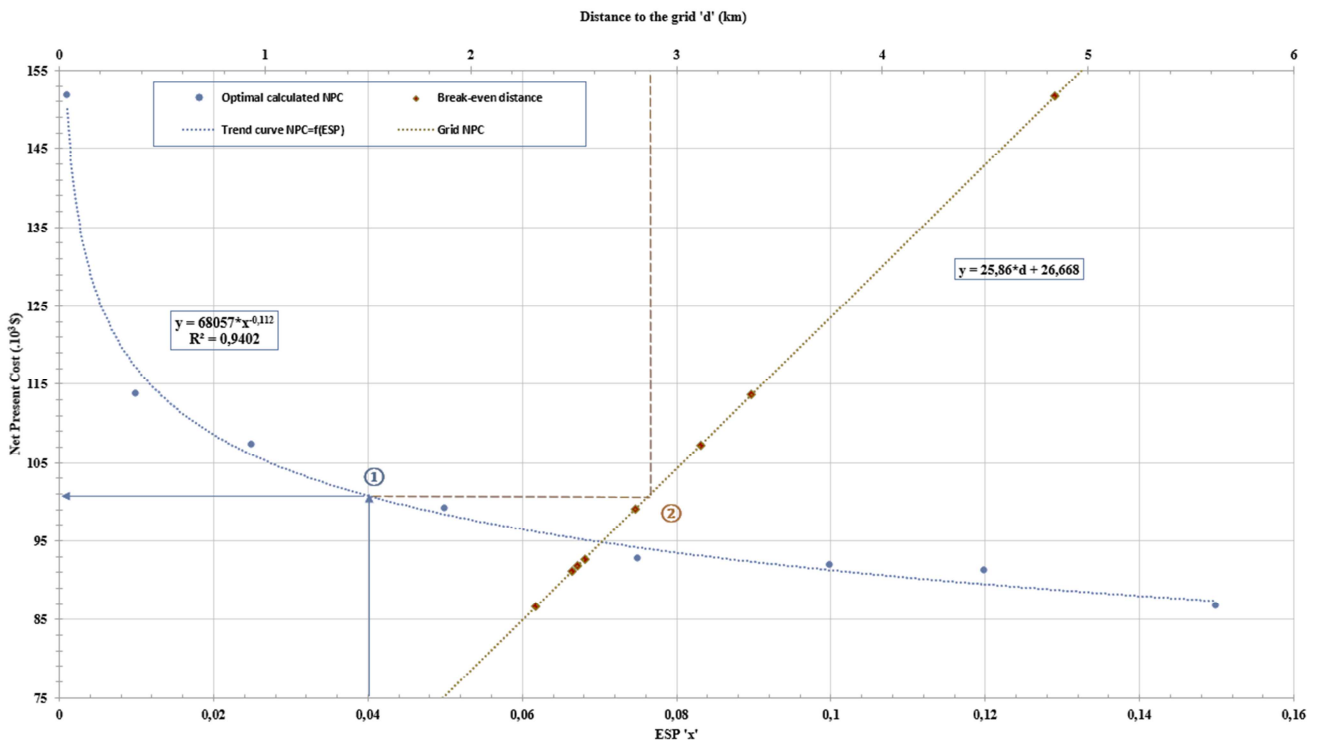

Figure 9. Optimal Wind-PV-battery and grid cost variation depending to ESP and distance.

Figure 9 shows the evolution of the total cost of hybrid system according to ESP and grid depending to the distance of connection to the grid. Intersection between grid cost and system cost for a given ESP return the break-even distance for the set reliability. It also shows the evolution of the break-even distance for decreasing ESP. More reliability comes with higher price and smaller break-even distance. The cost of hybrid system increases hyperbolically with the increase of reliability which comes with smaller break-even distance.

The trend curve of the optimum NPC can then be separated in two part. The first part, for ESP between 0.15 and 0.5 where total cost varies linearly with the ESP. in this domain increasing reliability (decrease of ESP) correspond to a linear

increase of system overall cost. The second part, for ESP under 0.05 correspond to hyperbolic variation of NPC according to the shortage probability. The NPC growth much faster when the reliability increased. The Figure 9 can also be used to determine the break-even distance for a fixed value of ESP following the step 1 and 2 on the chart. It can be used to determined also, knowing the distance from the health centre to the grid, the equivalent ESP that can be reached for cost equivalent to grid extension cost.

The last step of the comparison between grid extension solution and hybrid system consist in analysing the quality of delivered electricity in terms of shortage and in term of delivered voltage.

First, we examine hourly shortage data from the optimal points simulation to see the energy shortage (ES) occurrences to reflect the non-delivered load. For this, we use the energy shortage map to see the evolution and intensity of the shortage periods [23] (Figure 12).

Secondary the Figure 13 shows the voltage variation for both PV system and Grid electricity observed during health centre monitoring. The grid delivers bad voltage quality as it

can be noticed the measured voltage on the grid regularly decreased and reaches 160 V for an expected value of 220 V. Due to the use of inverter the voltage in hybrid system case is almost constant at 220V.

To validate the methodologic approach of the present study we calculate the Levelized Cost Of Energy (LCOE) of the hybrid system.

Table 4. Calculated values o LCOE depending on ESP.

ESP	15,0%	12,0%	10,0%	7,5%	5,0%	2,5%	1,0%	0,1%
LCOE (\$/kWh)	0.48	0.49	0.50	0.49	0.52	0.54	0.58	0.74

The LCOE values obtained are in the range of values obtained in the literature. In Ghorbani and al. [12], authors obtained a value of 0.508 \$/kWh for LCOE at 2% of ESP. In others studies LCOE values ranging between 0.459 – 0.562 U\$/kWh have been obtained by authors for ESP between 3 and 6% [13, 15, 26].

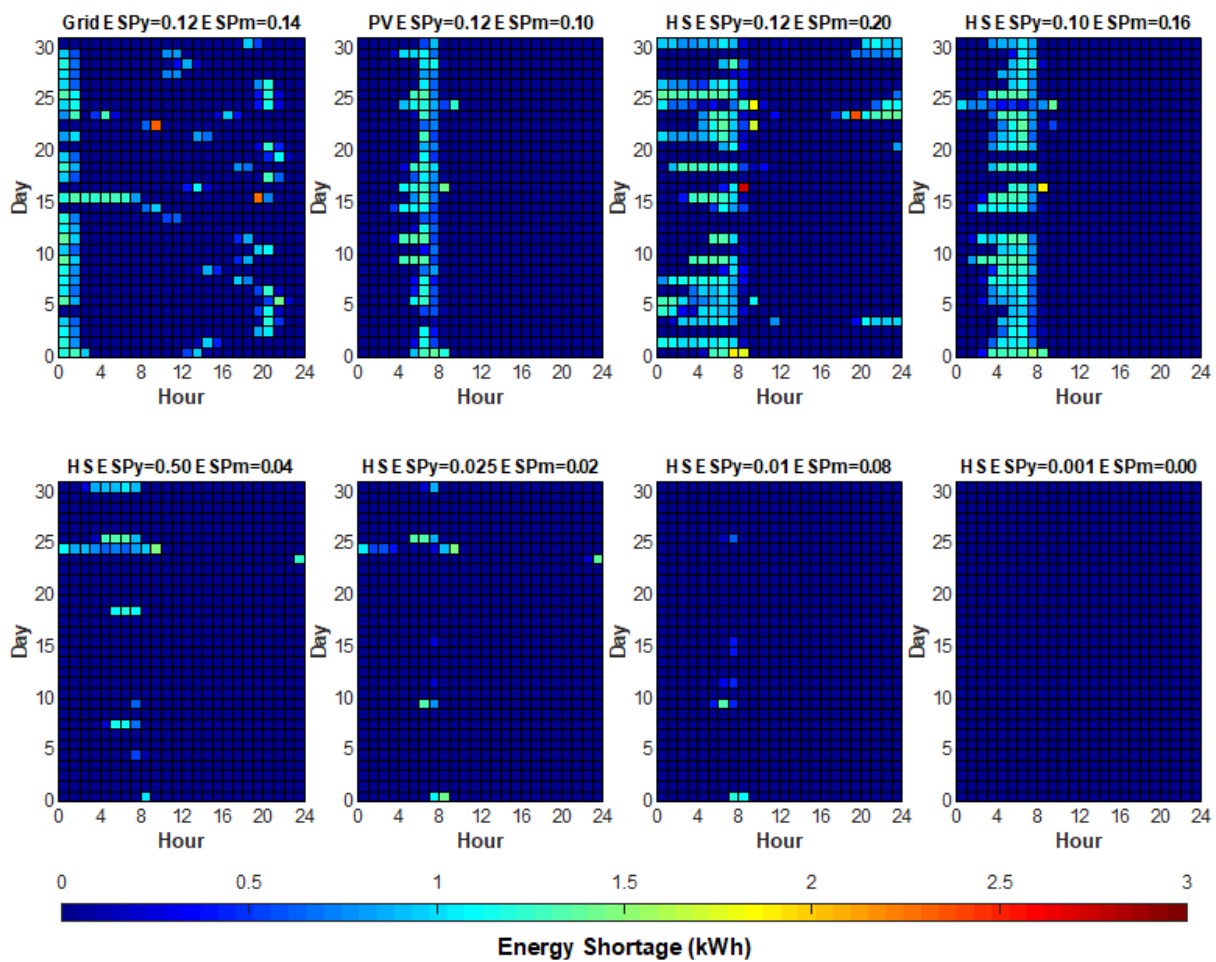

Figure 10. Comparison of the December shortage distribution for various systems.

The Figure 10 shows the map for the December month four different configurations. The month of December is chosen because according to Figure 8 it is the month with higher ESP in each optimal solution calculated. The three first maps represent the reliability obtain for Grid extension. PV system and wind-PV-battery all three with annual ESP equivalent to grid. ESP=0.12.

Contrary to renewable energy resources systems, the grid map shows random and unorganized energy shortage with no

specific pattern. Shortages in this case occurs every day at any time. Sometimes many times in the same day. The magnitude of the shortage (specified by colour cells) is in most cases, equivalent to the hourly load of the same period of time. With the same annual ESP, the PV system show shortage concentrated in the 4h to 8h period.

The wind-PV-battery system shows no shortage during working hours. For all the month. Five shortage happened during the evening period but maximum of the shortage are

concentrated in the 0 to 8 period. The other maps show evolution of the shortage when the annual reliability is increased (reducing annual ESP goal in optimization). With

successive values for ESP of 0.10 – 0.05 we see no more shortage in the evening period and the number of shortages in the night decrease under ten shortages between 0h and 8h.

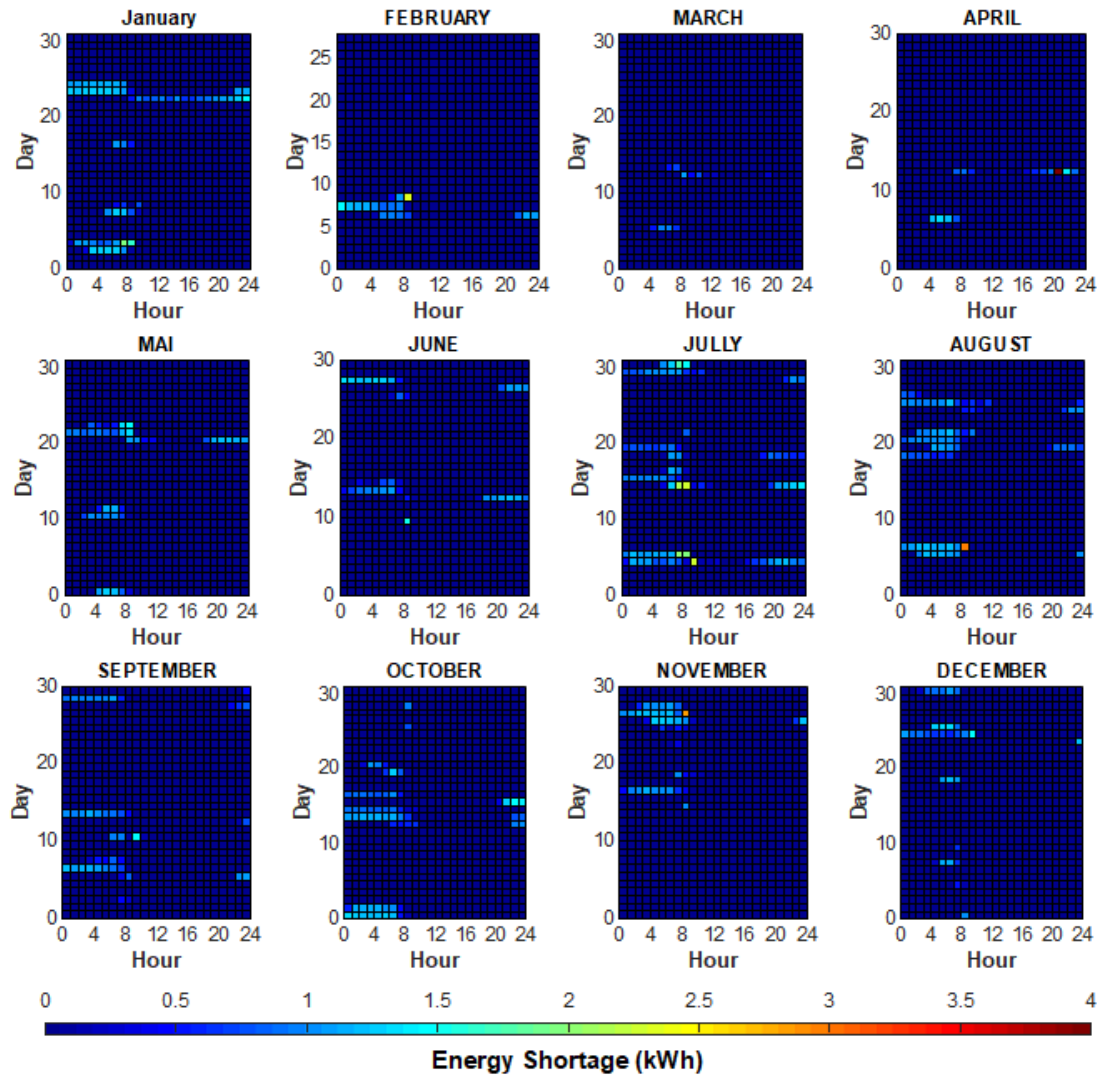

Figure 11. Monthly map of energy shortage for annual ESP=0.05.

The Figure 11 shows ES map for all the months for annual ESP of 0.05 (inflection point between linear evolution of price and hyperbolic growth). As the rural health centres need reliable and uninterrupted supply of electricity grid extension cannot be considered as solution in comparison of hybrid system with same annual ESP or less. Wind-PV-battery system with annual ESP of 0.05 can be considered a better solution. It offers the possibility off a cost-effective solution with large scarcity of shortage with an average 5 shortages a month. One can aim for more reliability but under ESP of 0.05 the net present cost of the system increases really fast with the ESP decreasing. Any few increase of reliability comes with large extra cost.

5. Conclusion

In conclusion, the obtained results show that at the current condition, blackout frequency, grid extension and components

prices, the wind-PV-battery hybrid system is cost and quality effective. Despite wind turbines commonly avoided in Benin due to weak potential, there is a good complementarity between both solar and wind resources. Optimizations performed for different level of accuracy in load delivery, proved it is better to complete PV system with a small-scale wind turbine, as the health care centre need continuous, uninterrupted and reliable electricity. Reliability and cost analysis, breakeven distance and supply electricity's quality, all plead for hybrid system use instead of grid extension. All rural health centre located more than 1km far from the grid should definitely switch for the hybrid system to produce their electricity. Even the health centre not connected or those connected which are aiming for more energy quality should also do the same. Therefore, there is a need of decision to organize access to electricity of those centres and maybe other public facilities for more accuracy in time, and reliable electricity using hybrid systems.

Appendix

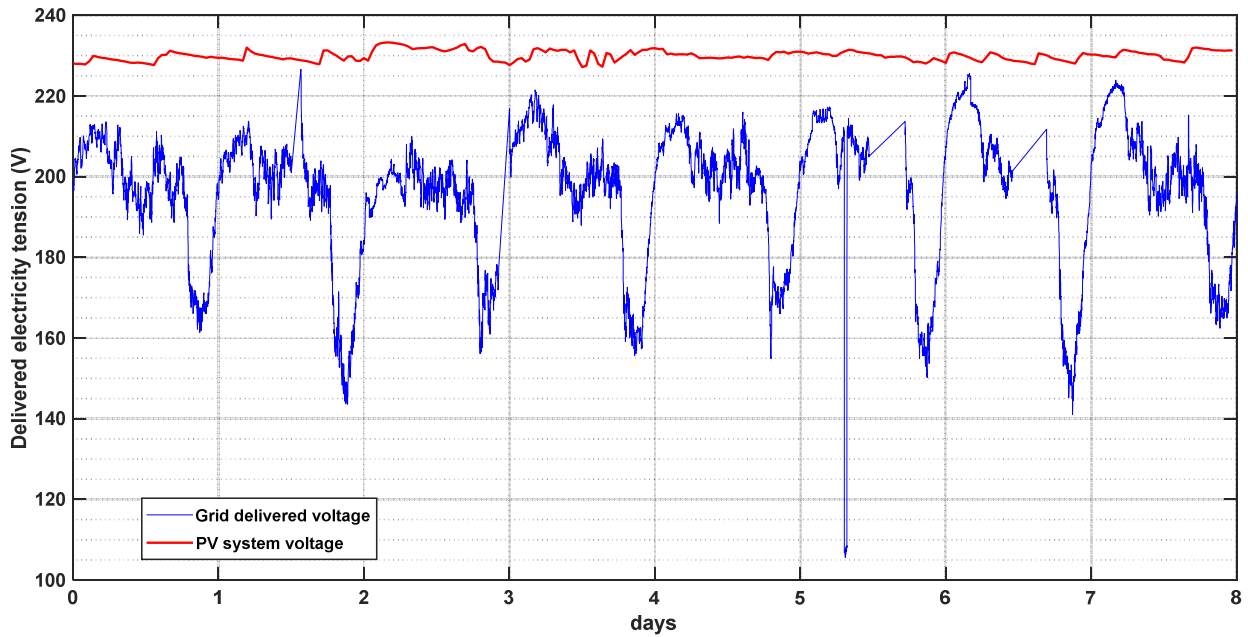

Figure 12. Voltage variation measured on grid and PV.

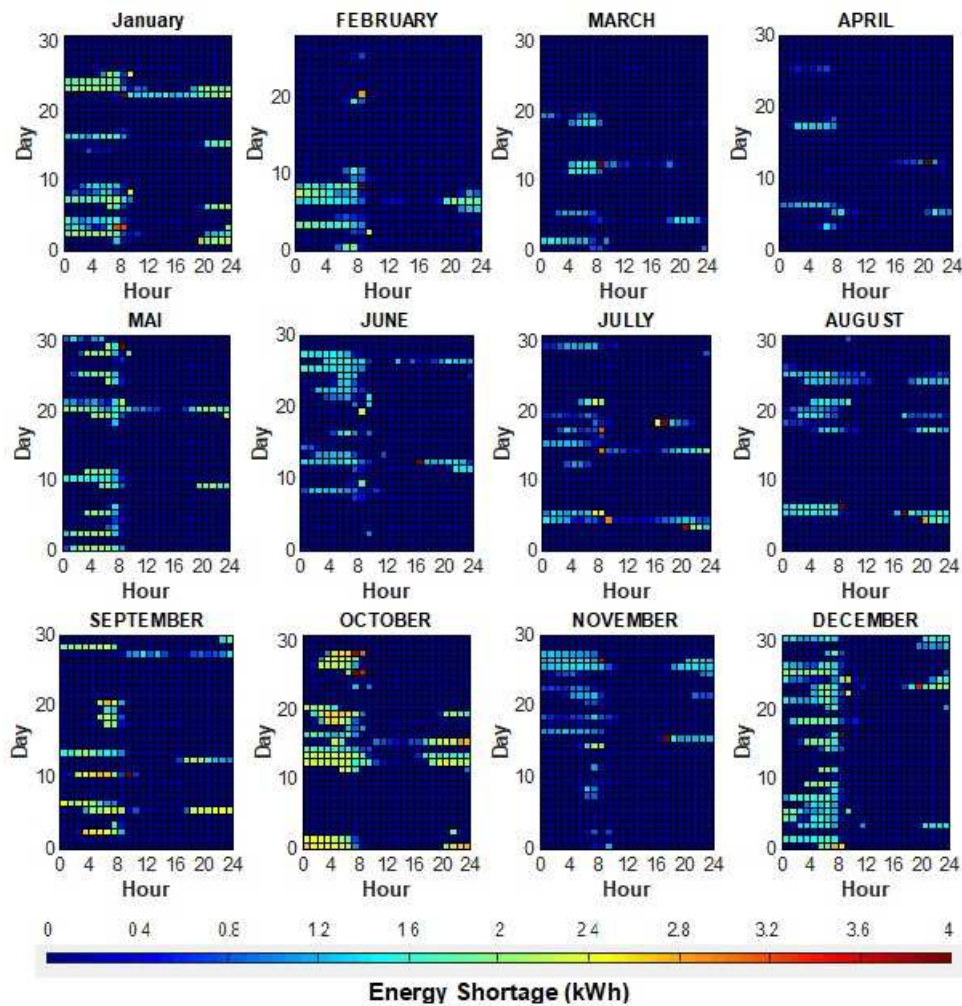

Figure 13. Energy shortage variation for $ESP_c=0.12$.

References

- [1] World Bank Open Data | Data, (n.d.). <https://data.worldbank.org/> (accessed May 5, 2019).
- [2] IEA Statistics, (n.d.). <http://www.iea.org/stats/index.asp> (accessed June 30, 2019).
- [3] H. Camblong, J. Sarr, A. T. Niang, O. Curea, J. A. Alzola, E. H. Sylla, M. Santos, Micro-grids project, Part 1: Analysis of rural electrification with high content of renewable energy sources in Senegal, *Renew. Energy*. 34 (2009) 2141–2150. doi: 10.1016/j.renene.2009.01.015.
- [4] S. Munuswamy, K. Nakamura, A. Katta, Comparing the cost of electricity sourced from a fuel cell-based renewable energy system and the national grid to electrify a rural health centre in India: A case study, *Renew. Energy*. 36 (2011) 2978–2983. doi: 10.1016/j.renene.2011.03.041.
- [5] O. Erdinc, M. Uzunoglu, Optimum design of hybrid renewable energy systems: Overview of different approaches, *Renew. Sustain. Energy Rev.* 16 (2012) 1412–1425. doi: 10.1016/j.rser.2011.11.011.
- [6] R. Luna-Rubio, M. Trejo-Perea, D. Vargas-Vázquez, G. J. Ríos-Moreno, Optimal sizing of renewable hybrids energy systems: A review of methodologies, *Sol. Energy*. 86 (2012) 1077–1088. doi: 10.1016/j.solener.2011.10.016.
- [7] C. Green, K. A. Byrne, Biomass: Impact on Carbon Cycle and Greenhouse Gas Emissions, in: E.-C. C. J. Cleveland (Ed.), *Encycl. Energy*, Elsevier, New York, 2004: pp. 223–236. <http://www.sciencedirect.com/science/article/pii/B012176480X004186>.
- [8] L. Olatomiwa, R. Blanchard, S. Mekhilef, D. Akinyele, Hybrid renewable energy supply for rural healthcare facilities: An approach to quality healthcare delivery, *Sustain. Energy Technol. Assess.* 30 (2018) 121–138. doi: 10.1016/j.seta.2018.09.007.
- [9] M. Cloutier, P. Rowley, The feasibility of renewable energy sources for pumping clean water in sub-Saharan Africa: A case study for Central Nigeria, *Renew. Energy*. 36 (2011) 2220–2226. doi: 10.1016/j.renene.2010.12.019.
- [10] A. S. Al Busaidi, H. A. Kazem, A. H. Al-Badi, M. Farooq Khan, A review of optimum sizing of hybrid PV–Wind renewable energy systems in oman, *Renew. Sustain. Energy Rev.* 53 (2016) 185–193. doi: 10.1016/j.rser.2015.08.039.
- [11] K. Anoune, M. Bouya, A. Astito, A. B. Abdellah, Sizing methods and optimization techniques for PV-wind based hybrid renewable energy system: A review, *Renew. Sustain. Energy Rev.* 93 (2018) 652–673. doi: 10.1016/j.rser.2018.05.032.
- [12] N. Ghorbani, A. Kasaeian, A. Toopshekan, L. Bahrami, A. Maghami, Optimizing a hybrid wind-PV-battery system using GA-PSO and MOPSO for reducing cost and increasing reliability, *Energy*. 154 (2018) 581–591. doi: 10.1016/j.energy.2017.12.057.
- [13] E. Muh, F. Tabet, Comparative analysis of hybrid renewable energy systems for off-grid applications in Southern Cameroons, *Renew. Energy*. 135 (2019) 41–54. doi: 10.1016/j.renene.2018.11.105.
- [14] M. Belouda, M. Hajjaji, H. Sliti, A. Mami, Bi-objective optimization of a standalone hybrid PV–Wind–battery system generation in a remote area in Tunisia, *Sustain. Energy Grids Netw.* 16 (2018) 315–326. doi: 10.1016/j.segan.2018.09.005.
- [15] S. Bhattacharjee, S. Acharya, PV–wind hybrid power option for a low wind topography, *Energy Convers. Manag.* 89 (2015) 942–954. doi: 10.1016/j.enconman.2014.10.065.
- [16] G. Prasad, Energy sector reform, energy transitions and the poor in Africa, *Energy Policy*. 36 (2008) 2806–2811. doi: 10.1016/j.enpol.2008.02.042.
- [17] 2019 Conference, Powering Health Care. (n.d.). <http://poweringhc.org/conference/> (accessed May 5, 2019).
- [18] M.-P. Kieny, T. G. Evans, S. Scarpetta, E. T. Kelley, N. Klazinga, I. Forde, J. H. M. Veillard, S. Leatherman, S. Syed, S. M. Kim, S. B. Nejad, L. Donaldson, Delivering quality health services: a global imperative for universal health coverage, *The World Bank*, 2018. <http://documents.worldbank.org/curated/en/482771530290792652/Delivering-quality-health-services-a-global-imperative-for-universal-health-coverage> (accessed May 5, 2019).
- [19] J. Peters, C. Vance, M. Harsdorff, Grid Extension in Rural Benin: Micro-Manufacturers and the Electrification Trap, *World Dev.* 39 (2011) 773–783. doi: 10.1016/j.worlddev.2010.09.015.
- [20] M. Aza-Gnandji, F. Xavier Fifatin, A. Hounnou, F. Dubas, D. Chamagne, C. Espanet, A. Vianou, Complementarity between Solar and Wind Energy Potentials in Benin Republic, 2018. doi: 10.4028/www.scientific.net/AEF.28.128.
- [21] Benin Data, (n.d.). <https://data.worldbank.org/country/benin> (accessed July 1, 2019).
- [22] Benin Inflation Rate 2019 Data Chart Calendar Forecast News, (n.d.). <https://tradingeconomics.com/benin/inflation-cpi?continent=america> (accessed July 1, 2019).
- [23] M. Lee, D. Soto, V. Modi, Cost versus reliability sizing strategy for isolated photovoltaic micro-grids in the developing world, *Renew. Energy*. 69 (2014) 16–24. doi: 10.1016/j.renene.2014.03.019.
- [24] Z. Wissem, K. Gueorgui, K. Hédi, Modeling and technical–economic optimization of an autonomous photovoltaic system, *Energy*. 37 (2012) 263–272. doi: 10.1016/j.energy.2011.11.036.
- [25] M. Wetter, Simulation Research Group Building Technologies Department Environmental Energy Technologies Division Lawrence Berkeley National Laboratory Berkeley, CA 94720, (n.d.) 109.
- [26] E. O. Diemuodeke, A. Addo, C. O. C. Oko, Y. Mulugetta, M. M. Ojapah, Optimal mapping of hybrid renewable energy systems for locations using multi-criteria decision-making algorithm, *Renew. Energy*. 134 (2019) 461–477. doi: 10.1016/j.renene.2018.11.055.